

**Overview**

The Focus Display range is designed for cost-effective hot food storage, transport and service. The units feature force air heating and recirculation which offers new levels of energy saving efficiency, faster heat-up times, quicker heat recovery times and even distribution of heat with no hot-spots. Stainless steel sliding doors lift off for maintenance and cleaning, inside panels are bright polished stainless steel. Rodded shelves allow for good heated air circulation.



**Key Features:**

- Hot Cupboards with Plain stainless steel tops
- Dry heat, Bain-Marie tops take gastronorm containers (not supplied)
- Front and end panels in Merlin Grey durable plastic coated steel
- Bright polished stainless steel interior
- Two grid shelves with heavy duty supports
- Fitted with two metre cable and plug for 13amp supply
- Complete with 125mm diameter swivel castors, 2 with brakes

**Benefits:**

- Economic to buy, economic to operate
- Even temperatures throughout
- Fan assisted heating system lifts out for maintenance and cleaning
- Doors lift off for cleaning



**Innovation**

This unit features Versigen's renowned, Sahara fan heating cell.

Model Code	Weight (kg)	Length (mm)	Width (mm)	Height (mm)	Rating (kw)
2FCHM	54	800	665	900	1.0
3FCHM	63	1085	665	900	2.0
4FCHM	73	1413	665	900	2.0
2FBM	54	800	665	900	2.0
3FBM	63	1085	665	900	2.0
4FBM	73	1413	665	900	2.0

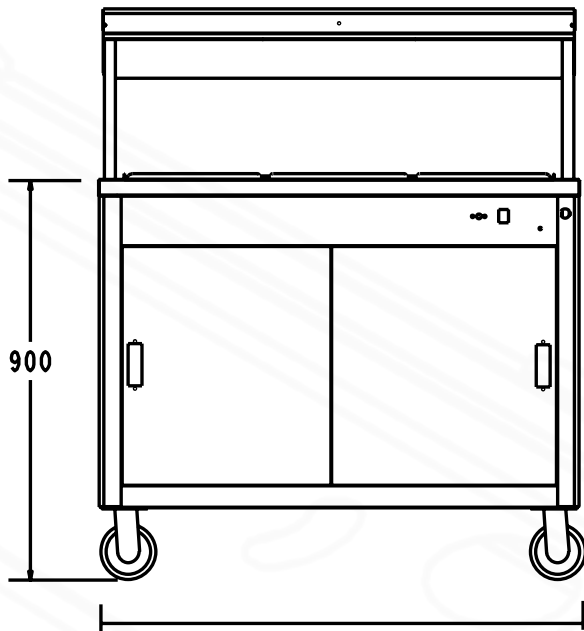

SIZE-2 800mm  
 SIZE-3 1085mm  
 SIZE-4 1413mm

