

Note
 When used as a Wet Heat
 The unit is manually filled with water. Capacity 20 litre
 A depth of 20mm must be maintained during operation.
 [water level marker fitted to side of the well]

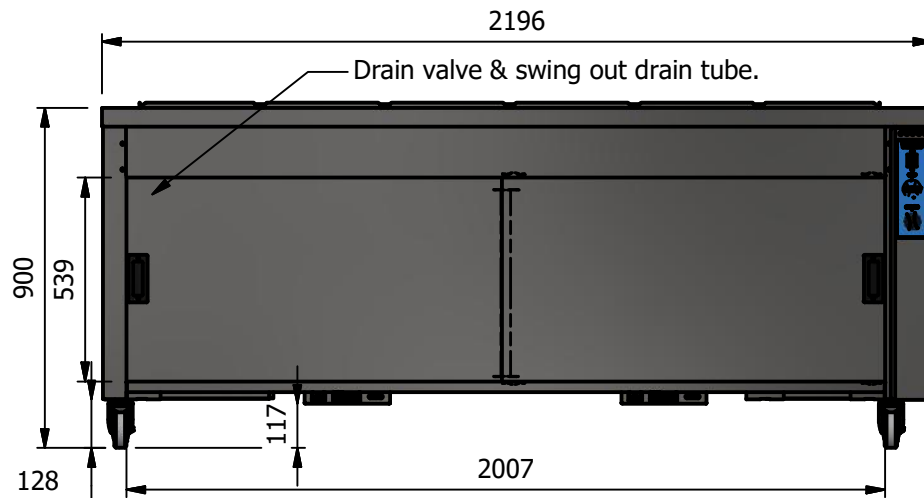
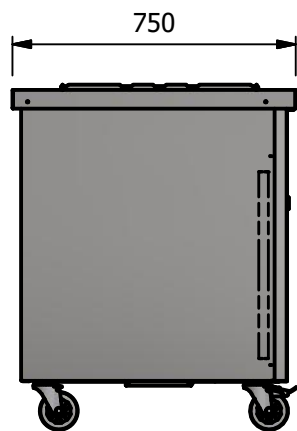
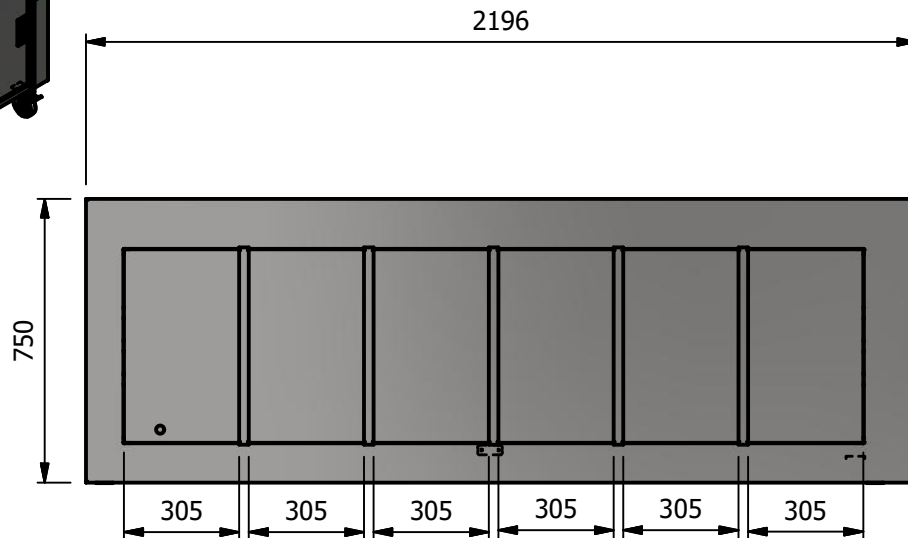

Moffat Specification

Bainmarie well "wet or dry"

Can be used dry heat or wet heat using hot water and steam.
 The open bath is designed to hold Gastronorm pans and heats via solid state elements fitted externally on the base of the bath, additional excess residual hot air from the hot cupboard is also used to maintain temperature which gives energy saving efficiency.

Dry Heat

Fan Assisted Hotcupboard



Sahara Fan Model SF309

Dimensions

Width - 2196mm
 Depth - 750mm
 Height - 900mm
 Weight - 138kg

Capacity of Bainmarie

Six GN1/1 pans up to 150mm deep

Capacity of Hot Cupboard [usable inside space]

Width - 2007mm
 Depth - 555mm
 Height Bottom shelf - 170mm
 Height Top Shelf - 240mm

70 covers & meals [10" plated meals stacked using plate covers]
 or
 266 off 10" plates stacked for heating
 or
 12 off 1/1GN pans side by side 150mm deep 6 on top 6 on bottom

Power Rating

3.8kw
 complete with a 2m long cord set & 20amp plug. Removable Fan heating System Sahara Fan Model SF309

Materials

1.2mm 304 Grade St/ Steel Top & Supports
 0.7mm 430 Grade St/ Steel Internal Structure
 GN 1/1 Grid Shelves with 30mm x 30mm tube supports

Installation

All swivel castors, two braked

ALL SHEET METAL DIMENSIONS ARE I/S (INSIDE SIZES) (UNLESS OTHERWISE STATED)

ALL DIMENSIONS IN (mm), TOLERANCE = LINEAR ± 0.5mm, ANGULAR ± 0.5mm (OR AS STATED). ALL SHARP EDGES TO BE REMOVED FROM SHEET METAL PARTS

Product		Product No			
Description		HB6EWD			
Material/Finish	Thickness	Desp/Date		<small>No reproduction or publication of this drawing may be made, and no article may be manufactured or assembled in accordance with this drawing without prior written consent. This prohibition is a term of any contract relating to this drawing. Rights reserved under the Copyright Act 1956 as amended by the Design Copyright Act 1968.</small>	
Legacy P/N	Weight	Quote No.			
Client	SO Number		Drawn By	HB6EWD	-
Client Project	Approved By		Date	02/09/2019	
VERSIGEN AUSTRALIA PTY LTD, 182 HARTLEY ROAD, SMEATON GRANGE, NSW 2567, T: +61 (0)131 653 330, E: sales@versigen.com.au, Web: www.versigen.com.au				Scale	1 : 20
				Sheet	1 / 1
					A4