

**Specification**

Solid Stainless Steel Worktop  
 Insulated for efficiency  
 provides a clean serving area.

Dry Heat  
 Fan Assisted Hotcupboard

Dimensions  
 Width - 1275mm  
 Depth - 700mm  
 Height - 900mm  
 Weight - 78kg

Capacity of Hot Cupboard [usable inside space]  
 Width - 1023mm  
 Depth - 559mm  
 Usable Height Bottom shelf - 210mm  
 Usable Height Top Shelf - 195mm

35 covers & meals [10" plated meals stacked using plate covers]  
 or  
 133 off 10" plates stacked for heating  
 or  
 6 off 1/1GN pans side by side 150mm deep 3 on top 3 on bottom

Power Rating  
 1.5kw.  
 complete with a 2m long cord set & 13amp plug  
 Removable Fan heating System Sahara Fan Model SF315

Materials  
 1.2mm 304 Grade St/ Steel Top & Supports  
 0.7mm 430 Grade St/ Steel Internal Structure  
 GN 1/1 Grid Shelves with 30mm x 30mm tube supports

Installation  
 All swivel castors, two braked

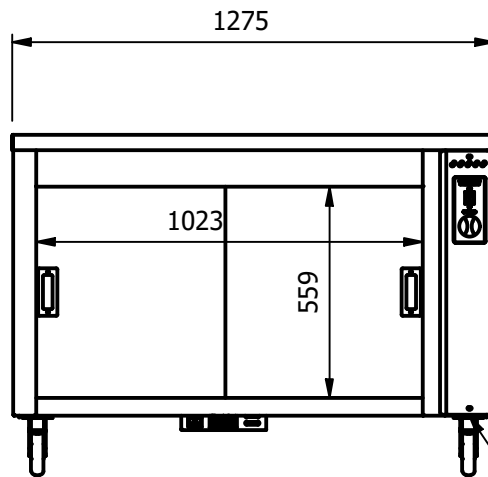

POWER CABLE  
 ENTRY POINT

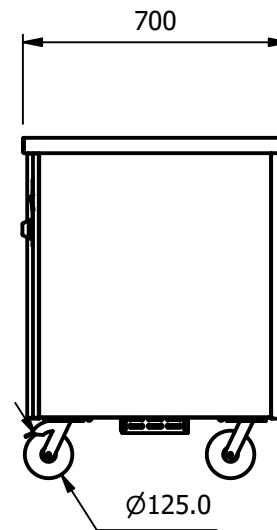

ALL SHEET METAL DIMENSIONS ARE I/S (INSIDE SIZES) (UNLESS OTHERWISE STATED)

ALL DIMENSIONS IN (mm), TOLERANCE = LINEAR ± 0.5mm, ANGULAR ± 0.5mm (OR AS STATED). ALL SHARP EDGES TO BE REMOVED FROM SHEET METAL PARTS

Product	COUNTERS			Product No	 <p>No reproduction or publication of this drawing may be made, and no article may be manufactured or assembled in accordance with this drawing without prior written consent. This prohibition is a term of any contract relating to this drawing. Rights reserved under the Copyright Act 1956 as amended by the Design Copyright Act 1968.</p>			
Description	HC3DBS-7							
Material/Finish	Thickness		Desp/Date		Dwg No.	CTRP-113670-1	Issue	
Legacy P/N	Weight	78kg	Quote No.		Drawn By	ABB	-	
Client			SO Number	N/A	Date	28/06/2021		
Client Project			Approved By		Scale	1 : 20	Sheet	
Versigen Foodservice Equipment 1/182 Hartley Road Smeaton Grange NSW 2567 Tel: 1300 653 330 Email: sales@versigen.com.au							1 / 2	<b>A4</b>