

Important Design Parameters

Allow a minimum air space of 15mm all round for easy slide in under counter.

Warning

Ideally the electrical socket fitted in the counter would be recessed
Be aware allowances must be made for any protruding power outlets etc.

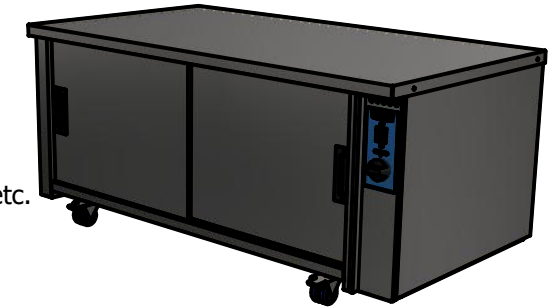

Also suitable for a counter set at 850mm high

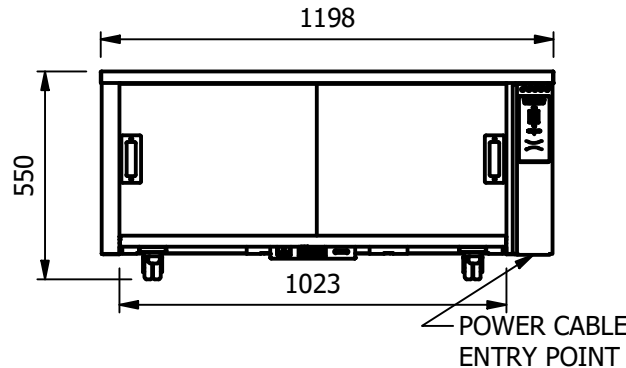
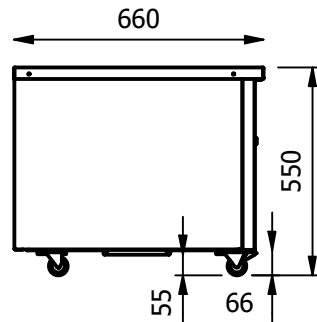
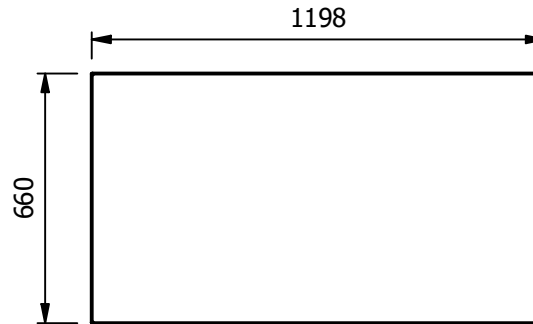

Versigen Specification

- Dry Heat
Fan Assisted Hotcupboard

- Dimensions
Width - 1198mm
Depth - 660mm
Height - 550mm
Weight - 49kg

- Capacity [usable inside space]
Width - 1023mm
Depth - 545mm
Height - 306mm

- Power Rating
1.5kw
complete with a 2m long cord set & 10amp plug
Removable Fan heating System Sahara Fan Model SF315

- Materials
1.2mm 304 Grade St/ Steel Top & Supports
0.7mm 430 Grade St/ Steel Internal Structure
GN 1/1 Grid Shelves with 30mm x 30mm tube supports

- Installation
RollUnder
All swivel castors, two braked

Minimum Under Counter Void Space
Dimensions
Width - 1228mm
Depth - 675mm
Height - 565mm

ALL SHEET METAL DIMENSIONS ARE I/S (INSIDE SIZES) (UNLESS OTHERWISE STATED)

ALL DIMENSIONS IN (mm), TOLERANCE = LINEAR ± 0.5mm, ANGULAR ± 0.5mm (OR AS STATED). ALL SHARP EDGES TO BE REMOVED FROM SHEET METAL PARTS

Product	ROLL UNDER HOTCUPBOARD			Product No	N/A				
Description	HC3RU			<small>No reproduction or publication of this drawing may be made, and no article may be manufactured or assembled in accordance with this drawing without prior written consent. This prohibition is a term of any contract relating to this drawing. Rights reserved under the Copyright Act 1956 as amended by the Design Copyright Act 1968.</small>					
Material/Finish	Thickness		Desp/Date						
Legacy P/N	Weight	49kg	Quote No.						
Client			SO Number	STD	Dwg No.	CTRP-078307	Issue		
Client Project			Approved By		Drawn By	N.Raymen	-		
VERSIGEN AUSTRALIA PTY LTD, 182 HARTLEY ROAD, SMEATON GRANGE, NSW 2567, T: +61 (0)131 653 330, E: sales@versigen.com.au, Web: www.versigen.com.au					Date	25/08/2020			
					Scale	1 : 20	Sheet	1 / 2	A4