

Specification

Solid Stainless Steel Worktop
 Insulated for efficiency
 provides a clean serving area.

Dry Heat
 Fan Assisted Hotcupboard

Dimensions
 Width - 1603mm
 Depth - 700mm
 Height - 900mm
 Weight - 95kg

Capacity of Hot Cupboard [usable inside space]
 Width - 1351mm
 Depth - 555mm
 Usable Height Bottom shelf - 210mm
 Usable Height Top Shelf - 195mm

50 covers & meals [10" plated meals stacked using plate covers]
 or
 190 off 10" plates stacked for heating
 or
 8 off 1/1GN pans side by side 150mm deep 4 on top 4 on bottom

Power Rating
 1.5kw.
 complete with a 2m long cord set & 13amp plug
 Removable Fan heating System Sahara Fan Model SF315

Materials
 1.2mm 304 Grade St/ Steel Top & Supports
 0.7mm 430 Grade St/ Steel Internal Structure
 GN 1/1 Grid Shelves with 30mm x 30mm tube supports

Installation
 All swivel castors, two braked

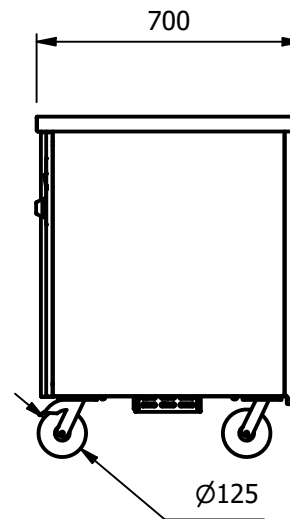
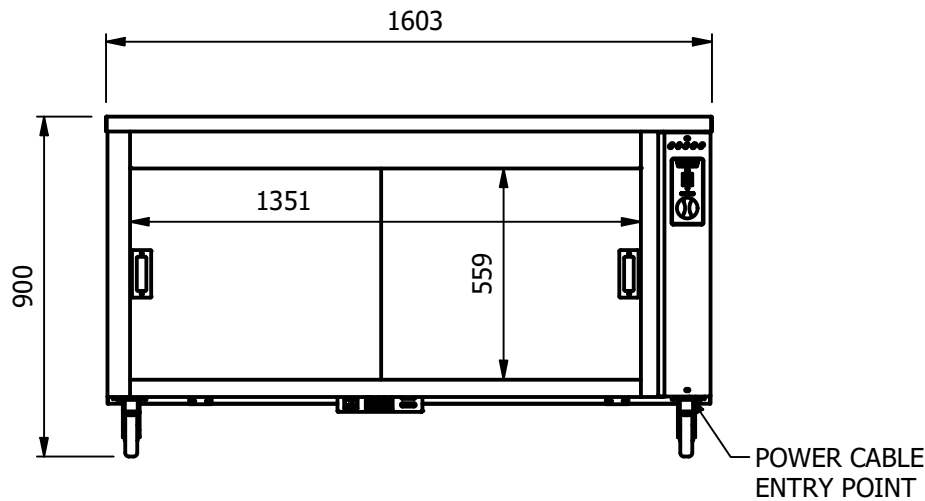

ALL SHEET METAL DIMENSIONS ARE I/S (INSIDE SIZES) (UNLESS OTHERWISE STATED)

ALL DIMENSIONS IN (mm), TOLERANCE = LINEAR ± 0.5mm, ANGULAR ± 0.5mm (OR AS STATED). ALL SHARP EDGES TO BE REMOVED FROM SHEET METAL PARTS

Product	COUNTERS			Product No				
Description	HC4-7							
Material/Finish	Thickness		Desp/Date		<small>No reproduction or publication of this drawing may be made, and no article may be manufactured or assembled in accordance with this drawing without prior written consent. This prohibition is a term of any contract relating to this drawing. Rights reserved under the Copyright Act 1956 as amended by the Design Copyright Act 1968.</small>			
Legacy P/N	Weight	95kg	Quote No.					
Client			SO Number	N/A	Dwg No.	CTRP-113429-1	Issue	
Client Project			Approved By		Drawn By	ABB		
Versigen Foodservice Equipment 1/182 Hartley Road Smeaton Grange NSW 2567 Tel: 1300 653 330 Email: sales@versigen.com.au					Date	28/06/2021		
					Scale	1 : 20	Sheet	1 / 2
								A4