

**Important Design Parameters**  
 Allow a minimum air space of 15mm all round for easy slide in under counter.

**Warning**  
 Ideally the electrical socket fitted in the counter would be recessed  
 Be aware allowances must be made for any protruding power outlets etc.

Also suitable for a counter set at 850mm high

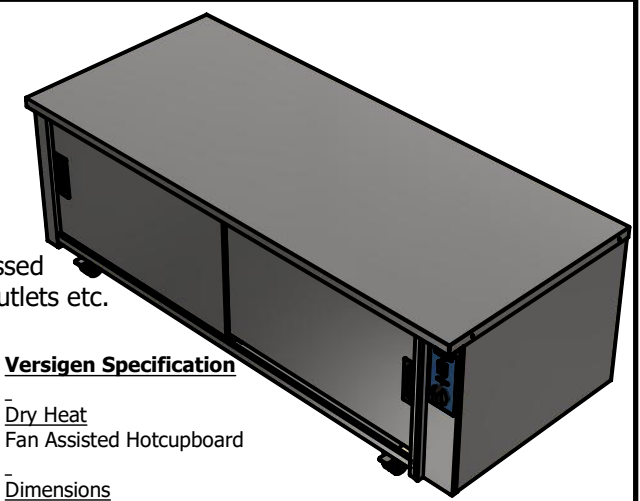
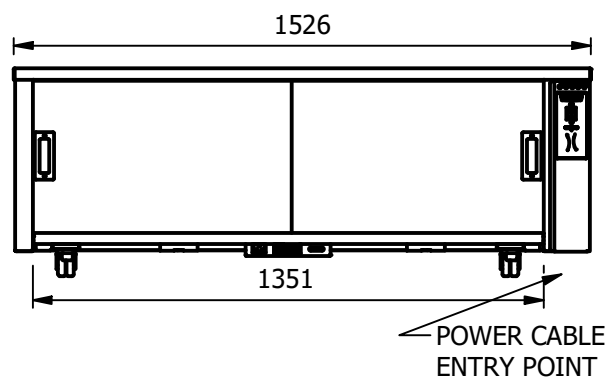
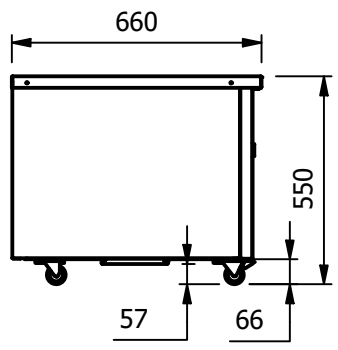
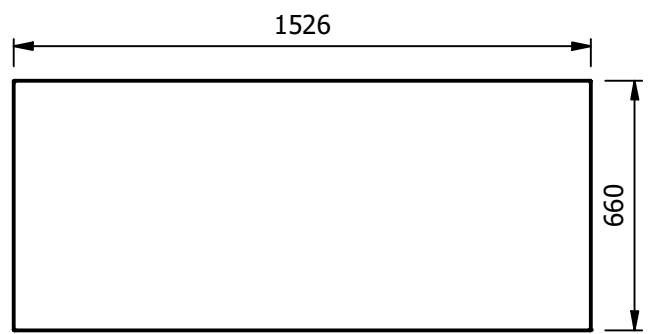

**Versigen Specification**

- Dry Heat  
 Fan Assisted Hotcupboard

- **Dimensions**  
 Width - 1526mm  
 Depth - 660mm  
 Height - 550mm  
 Weight - 65kg

- **Capacity [usable inside space]**  
 Width - 1351mm  
 Depth - 545mm  
 Height - 306mm

- **Power Rating**  
 1.5kw  
 complete with a 2m long cord set & 10amp plug  
 Removable Fan heating System Sahara Fan Model SF315

- **Materials**  
 1.2mm 304 Grade St/ Steel Top & Supports  
 0.7mm 430 Grade St/ Steel Internal Structure  
 GN 1/1 Grid Shelves with 30mm x 30mm tube supports

- **Installation**  
 RollUnder  
 All swivel castors, two braked

- **Minimum Under Counter Void Space**  
**Dimensions**  
 Width - 1556mm  
 Depth - 675mm  
 Height - 565mm



Sahara Fan Model SF315

ALL SHEET METAL DIMENSIONS ARE I/S (INSIDE SIZES) (UNLESS OTHERWISE STATED) ALL DIMENSIONS IN (mm), TOLERANCE = LINEAR ± 0.5mm, ANGULAR ± 0.5mm (OR AS STATED). ALL SHARP EDGES TO BE REMOVED FROM SHEET METAL PARTS

Product	ROLL UNDER HOTCUPBOARD			Product No	N/A			 FOODSERVICE EQUIPMENT
Description	HC4RU			Desp/Date				
Material/Finish	Thickness			Quote No.		Dwg No.	CTRP-079051	Issue
Legacy P/N	Weight	65kg		SO Number	STD	Drawn By	ABB	-
Client				Approved By		Date	14/08/2019	
Client Project						Scale	1 : 20	Sheet