

SEZIONE A-A

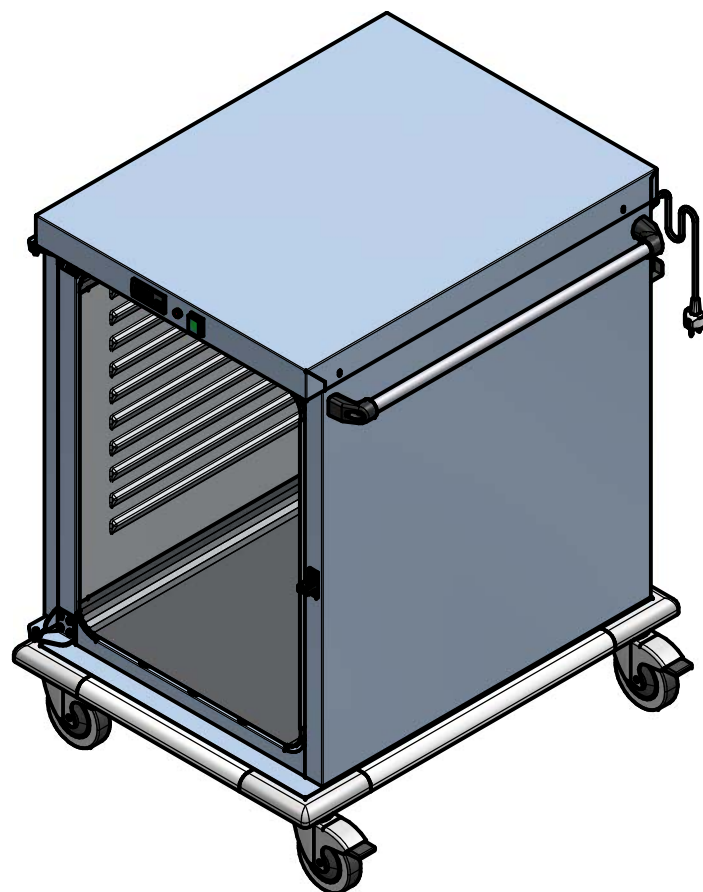

Versigen

Versigen foodservice equipment
1/182 Hartley Road
Smeaton Grange NSW 2567

www.versigen.com.au
sales@versigen.com.au
1300 653 330

| | | | | | |
|--|---|---------------------|----------------------|------|-------|
| <p>La quota di piega indica dove puntare l'utensile di piega</p> <p>Ove non indicato le pieghe sono da 90°</p> <p>Foglio 1/2</p> <p>Peso Pezzo :</p> <p>Peso Ingombro :</p> <p>Tolleranze generali: UNI EN 22768-2-K (geom.) UNI EN 22768-1-m (dimen.)</p> <p>File : 3421-10GS_01.dft</p> | Lavorazione | Scala 1:1 | | | 04 |
| | Materiale | Spessore | | | 03 |
| | BANQUET HOT CUPBOARD MC. 3421-10GS | | | | 02 |
| | METALCARRELLI SINCE 1964 | FIRMA FB | DATA 09.05.2018 | | 01 |
| | CODICE 3421-10GS_01 | REV. | DESCRIZIONE MODIFICA | DATA | FIRMA |