

**Versigen Specification**

- Dry Heat  
Fan Assisted Bainmarie Well

Dimensions

Width - 830mm  
Depth - 660mm  
Height - 701mm  
Weight - 30kg

Power Rating

1.12kw  
complete with a 2m long cord set & 10amp plug  
Removable Fan heating System Sahara Fan Model SF309

Materials

1.2mm 304 Grade St/ Steel Top & Supports  
0.7mm 430 Grade St/ Steel Internal Structure  
0.7mm Galvanised Steel Undercarrage  
6mm Tempered Glass  
Quartz Lamps

Installation

Counter Top Flush Fit Cut Out Dimensions  
836mm x 666mm x 25mm  
Counter Support Cut Out Dimensions  
812mm x 642mm

Sahara Fan Model SF309

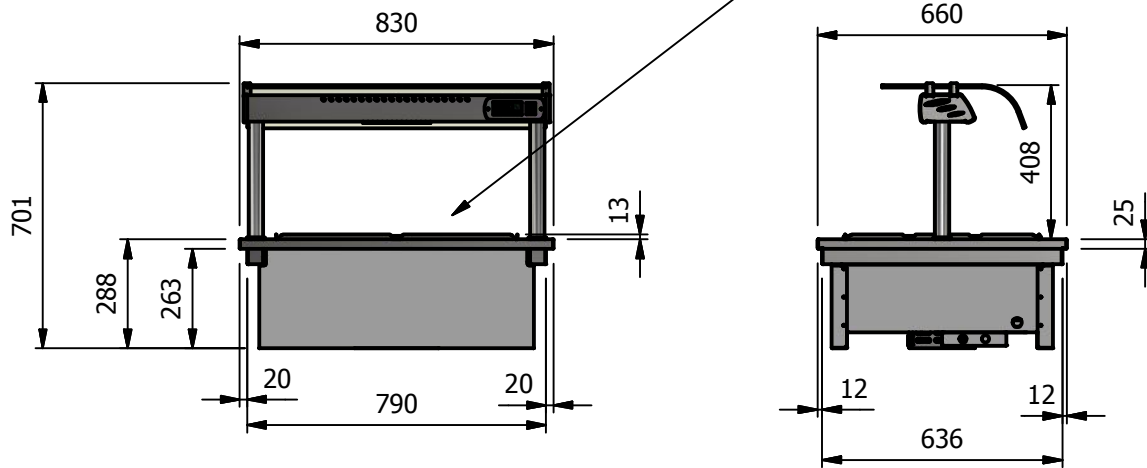

ALL SHEET METAL DIMENSIONS ARE I/S (INSIDE SIZES) (UNLESS OTHERWISE STATED)

ALL DIMENSIONS IN (mm), TOLERANCE = LINEAR ± 0.5mm, ANGULAR ± 0.5mm (OR AS STATED). ALL SHARP EDGES TO BE REMOVED FROM SHEET METAL PARTS

Product	DROP-IN RANGE			Product No	 FOODSERVICE EQUIPMENT				
Description	D2BM								
Material/Finish	Thickness		Desp/Date		<small>© No reproduction or publication of this drawing may be made, and no article may be manufactured or assembled in accordance with this drawing without prior written consent. This prohibition is a term of any contract relating to this drawing. Rights reserved under the Copyright Act 1956 as amended by the Design Copyright Act 1968.</small>				
Legacy P/N	Weight	30kg	Quote No.	Dwg No.					
Client			SO Number	N/A	DIP-020124				
Client Project			Approved By		Issue				
VERSIGEN AUSTRALIA PTY LTD, 182 HARTLEY ROAD, SMEATON GRANGE, NSW 2567, T: +61 (0)131 653 330, E: sales@versigen.com.au, Web: www.versigen.com.au					Scale	1:20	Sheet	1 / 2	A4