

A (1 : 10)

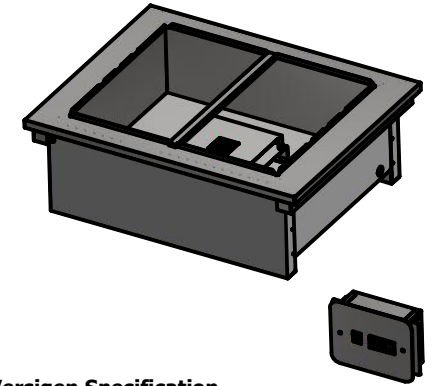
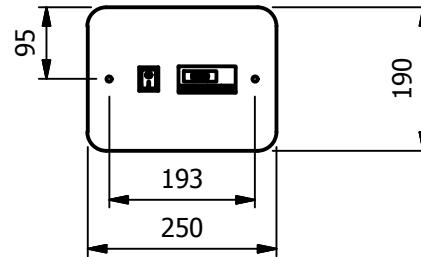

Versigen Specification

- Dry Heat
Fan Assisted Bainmarie Well

- Dimensions
Width - 830mm
Depth - 660mm
Height - 66mm
Weight - 23kg

- Power Rating
0.900 kw
complete with a 2m long cord set & 10amp plug
Removable Fan heating System Sahara Fan Model SF309

- Materials
1.2mm 304 Grade St/ Steel Top & Supports
0.7mm 430 Grade St/ Steel Internal Structure
0.7mm Galvanised Steel Undercarrage

- Installation
Counter Top Flush Fit Cut Out Dimensions
836mm x 666mm x 25mm
Counter Support Cut Out Dimensions
812mm x 642mm

- Control Box
Panel Mounted Cut Out Dimension
215mm x 165mm
2m Long Power Cable Connecting
Control Box to Base unit

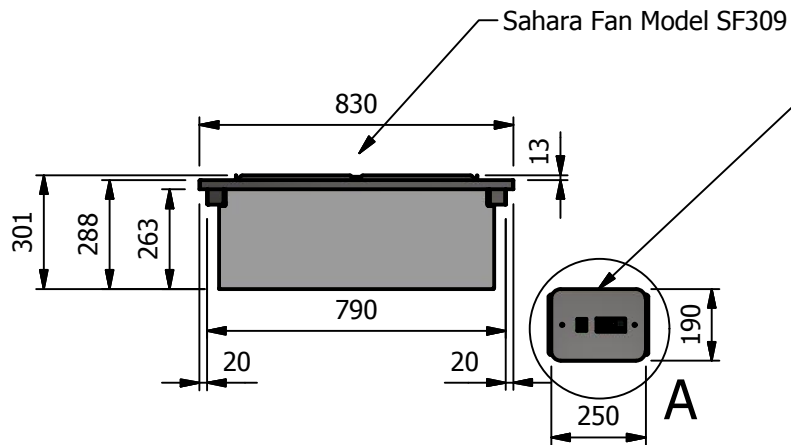

Panel Mounted Control Box

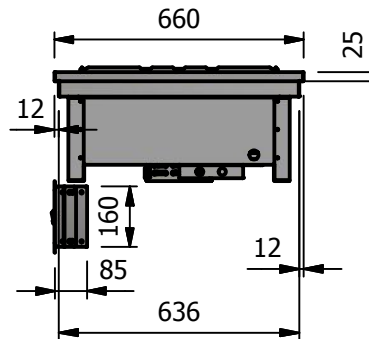

ALL SHEET METAL DIMENSIONS ARE I/S (INSIDE SIZES) (UNLESS OTHERWISE STATED)

ALL DIMENSIONS IN (mm), TOLERANCE = LINEAR ± 0.5mm, ANGULAR ± 0.5mm (OR AS STATED). ALL SHARP EDGES TO BE REMOVED FROM SHEET METAL PARTS

Product	DROP-IN RANGE			Product No	 FOODSERVICE EQUIPMENT
Description	D2BMNG				
Material/Finish	Thickness		Desp/Date		No reproduction or publication of this drawing may be made, and no article may be manufactured or assembled in accordance with this drawing without prior written consent. This prohibition is a term of any contract relating to this drawing. Rights reserved under the Copyright Act 1956 as amended by the Design Copyright Act 1968.
Legacy P/N	Weight	23kg	Quote No.	Dwg No.	
Client			SO Number	N/A	DIP-016606
Client Project			Approved By		Issue
VERSIGEN AUSTRALIA PTY LTD, 182 HARTLEY ROAD, SMEATON GRANGE, NSW 2567, T: +61 (0)131 653 330, E: sales@versigen.com.au, Web: www.versigen.com.au					Drawn By ABB Date 15/01/2019
					Scale
					1:20
					Sheet
					1 / 2
					A4