

A (1 : 10)

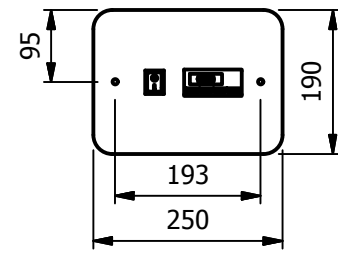

Versigen Specification

Dry Heat
Fan Assisted Bainmarie Well

Dimensions
Width - 1814mm
Depth - 660mm
Height - 66mm
Weight - 44kg

Power Rating
1.900 kw
complete with a 2m long cord set & 10amp plug
Removable Fan heating System Sahara Fan Model SF319

Materials
1.2mm 304 Grade St/ Steel Top & Supports
0.7mm 430 Grade St/ Steel Internal Structure
0.7mm Galvanised Steel Undercarrage

Installation
Counter Top Flush Fit Cut Out Dimensions
1820mm x 666mm x 25mm
Counter Support Cut Out Dimensions
1796mm x 642mm

Control Box
Panel Mounted Cut Out Dimension
215mm x 165mm
2m Long Power Cable Connecting
Control Box to Base unit

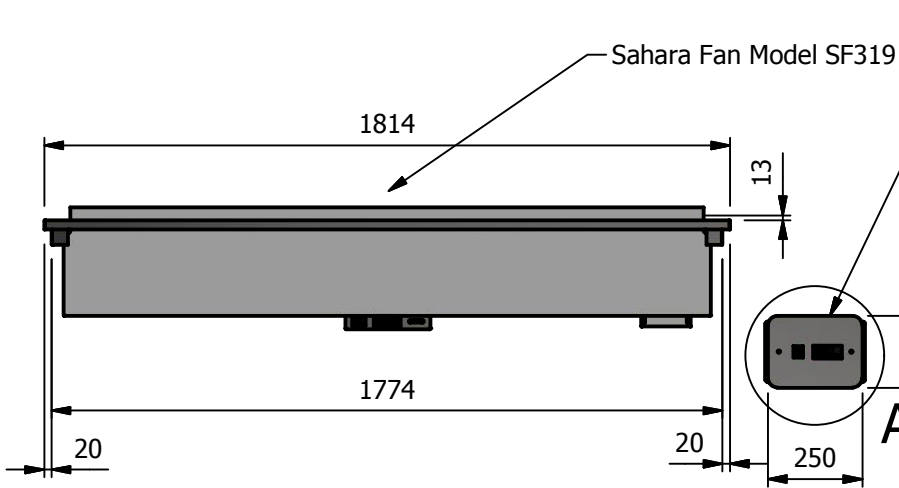

Panel Mounted Control Box

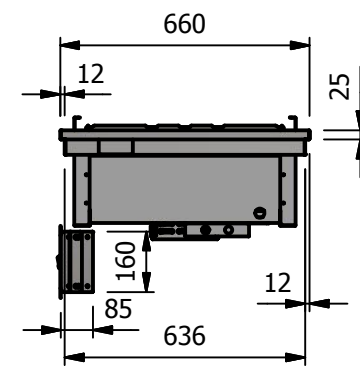

ALL SHEET METAL DIMENSIONS ARE I/S (INSIDE SIZES) (UNLESS OTHERWISE STATED) ALL DIMENSIONS IN (mm), TOLERANCE = LINEAR ± 0.5mm, ANGULAR ± 0.5mm (OR AS STATED). ALL SHARP EDGES TO BE REMOVED FROM SHEET METAL PARTS

Product	DROP-IN RANGE			Product No		<small>No reproduction or publication of this drawing may be made, and no article may be manufactured or assembled in accordance with this drawing without prior written consent. This prohibition is a term of any contract relating to this drawing. Rights reserved under the Copyright Act 1956 as amended by the Design Copyright Act 1968.</small>				
Description	D5BMNG									
Material/Finish	Thickness			Desp/Date		Dwg No.	DIP-016610	Issue		
Legacy P/N	Weight	44kg		Quote No.						
Client				SO Number	N/A	Drawn By	ABB	-		
Client Project				Approved By		Date	15/01/2019			
VERSIGEN AUSTRALIA PTY LTD, 182 HARTLEY ROAD, SMEATON GRANGE, NSW 2567, T: +61 (0)131 653 330, E: sales@versigen.com.au, Web: www.versigen.com.au						Scale	1:20	Sheet	1 / 2	A4