

Important Design Parameters

On the operators side of the Servery Counter a removable service panel is required to allow access to service heating elements etc. The dimensions of the access aperture must be no less than 1653mm x 145mm.

Additionally access is required to manually operate the drain valve. Drain connection is via 15mm lever ball valve.

Warning

The unit must be manually filled with water. Capacity 33 litre
A depth of 40mm must be maintained during operation.
[water level marker fitted to element cover]

Versigen Specification

- Wet Heat
Immersion heated Bainmarie Well

- Dimensions
Width - 1814mm
Depth - 660mm
Height - 666mm
Weight - 78kg

- Power Rating
5.88kw
complete with a 2m long cord set & 20amp plug

- Materials
1.2mm 304 Grade St/ Steel Top, Supports & Well
0.7mm 430 Grade St/ Steel External Structure
0.7mm Galvanised Steel Undercarrage
6mm Tempered Glass
Quartz Lamps

- Installation
Counter Top Flush Fit Cut Out Dimensions
1820mm x 666mm x 25mm
Counter Support Cut Out Dimensions
1796mm x 642mm

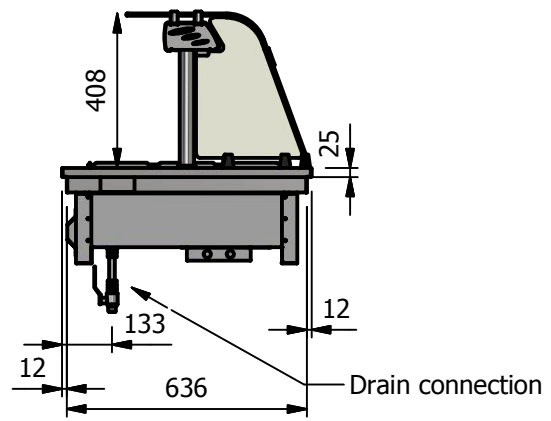
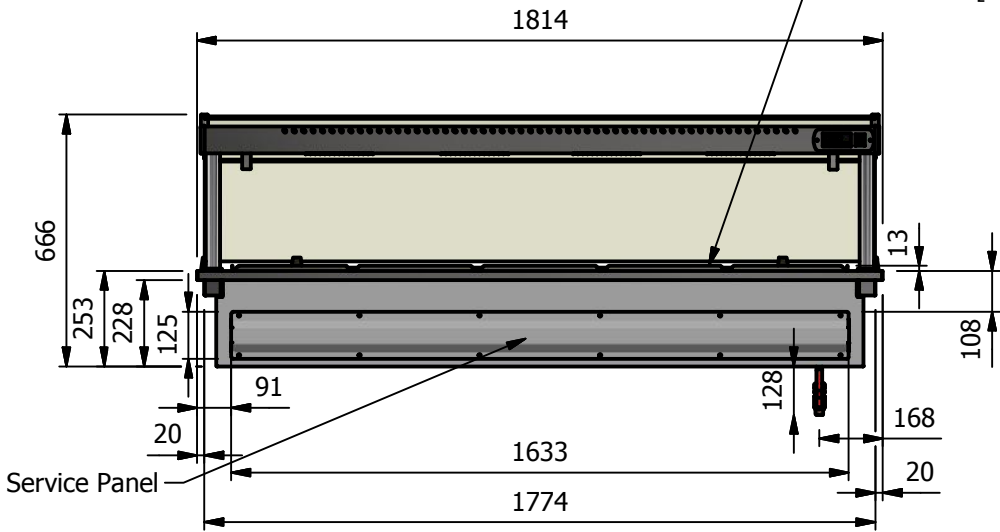

ALL SHEET METAL DIMENSIONS ARE I/S (INSIDE SIZES) (UNLESS OTHERWISE STATED) ALL DIMENSIONS IN (mm), TOLERANCE = LINEAR ± 0.5mm, ANGULAR ± 0.5mm (OR AS STATED). ALL SHARP EDGES TO BE REMOVED FROM SHEET METAL PARTS

Product	DROP-IN RANGE			Product No	 FOODSERVICE EQUIPMENT			
Description	D5BMWF							
Material/Finish	Thickness		Desp/Date		<small>No reproduction or publication of this drawing may be made, and no article may be manufactured or assembled in accordance with this drawing without prior written consent. This prohibition is a term of any contract relating to this drawing. Rights reserved under the Copyright Act 1956 as amended by the Design Copyright Act 1968.</small>			
Legacy P/N	Weight	78kg	Quote No.					
Client			SO Number	N/A	Dwg No.	DIP-022477	Issue	
Client Project			Approved By		Drawn By	ABB		
					Date	16/01/2019		