

**Overview**

Model designed for waste management, complete with multiple recycling bins and tray & plate return storage.

**“Get involved”**

Disposing of school waste in a cleaner, more sustainable way is now easier and cheaper with this specially designed mobile recycle station.

Involving teachers and children in recycling schemes to improve the environment can be fun. Educating children about the importance of recycling and the environment provides a path to a greener future.

Recycling schemes in schools are vital to help improve the environment and reduce spending on waste disposal.



**Key Features:**

- Special funnel and bin for liquids
- Designated bin for plastic
- Designated bin for paper
- Designated bin for food waste
- Designated bin for non recyclables (cutlery & beakers)
- Areas for plates or trays
- Shelf for resting and supporting tray while recycling
- Low maintenance, easy cleaned and highly efficient.
- Bins can be swapped out and replenished during service.
- Bins can be easily removed for easy cleaning
- Mobile all swivel castors two with brakes.

**Options:**

- Wide choice of coloured outer panles (Durable plastic coated steel).

**Note:**

A low height model is available set at 800mm high.

Ideal for children up to 12 years.

The low height model has a “B” added to the model code.



**Colour Code**

- Turquoise – Liquids
- Red – Plastics
- Blue – Paper
- Green – Food Waste
- Yellow – Non recyclable (cutlery)



Model	Weight (kg)	L x W x H (mm)
VCCS	65	1764 x 650 x 996
VCCSB	55	1764 x 650 x 896

Model VCCSB

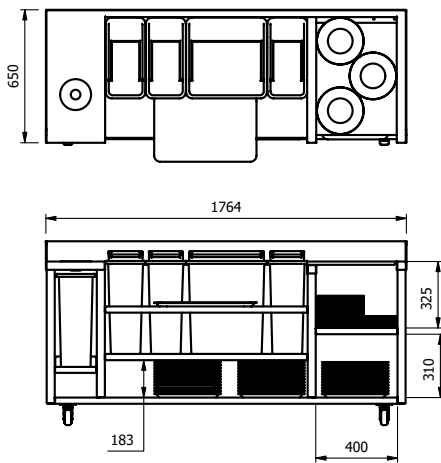

Model VCCS

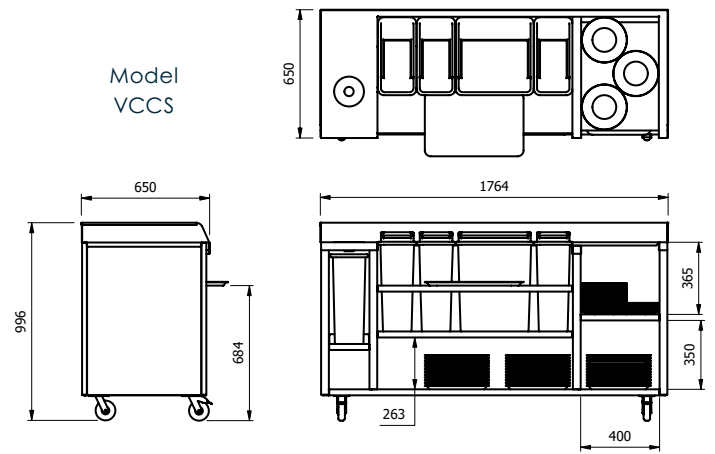

# REDUCE. REUSE. RECYCLE.



Liquids



Plastic



Paper



Food Waste



Re-Usable

