

Versigen

Premier Hot Cupboard & Bain-Marie/Hot Cupboard

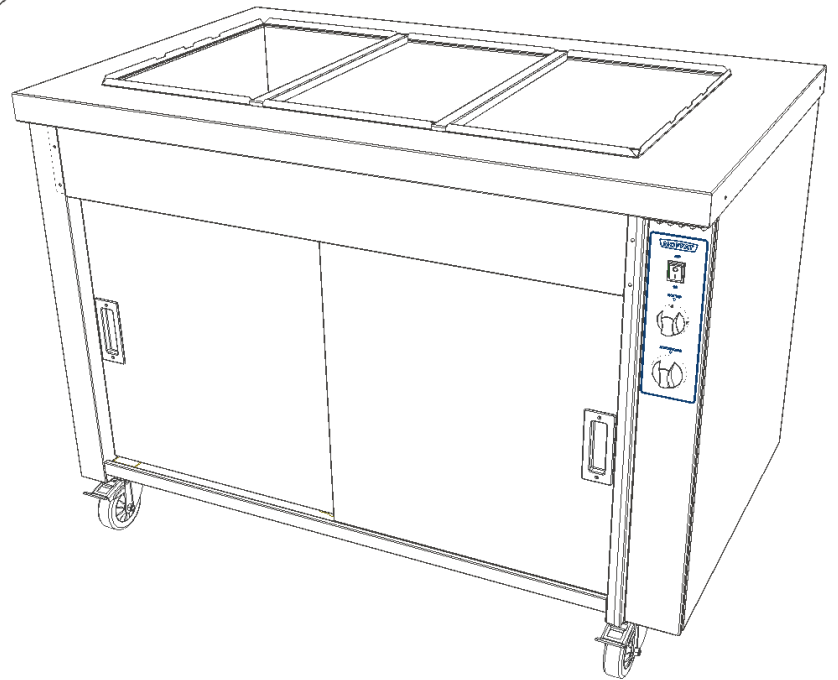

Operating & Service Manual

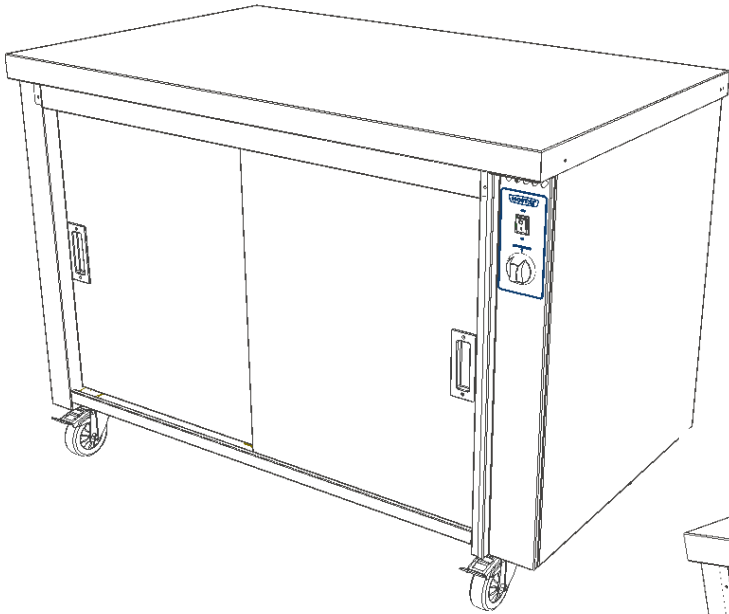

Please take the time to read and follow all safety, installation and maintenance guidelines





These appliances are marked in compliance with the relevant regulations, Voltage stated on unit data plate.



Warning! *Please pay attention to sections of the manual displaying this symbol.*



Warning! *Do not attempt to use a hose or water jet to clean this unit. For cleaning instructions, refer to section 6.*

The appliance must only be used for the purpose it was designed for and may become unsafe if used for any other purpose. Operators should be trained. The room where this trolley is used must be dry, clean with temperatures between 3°C and 26°C and with a maximum relative humidity of 60%. This unit is for indoor use only and has an IPX4 rating.

Prior to ANY service calls please:

- *Consult manual for basic fault-finding advice and information required to place the call*
- *Check warranty/maintenance terms and conditions*

“If the supply cord is damaged, it must be replaced by the manufacturer, service agent or suitably qualified person”

Appliance must be disconnected from the power supply during cleaning, maintenance and part - replacement”.

Contents

		<i>page</i>
1	Electrical	4
2	Specifications & Dimensions	5
3	Operation: Hotcupboard	6
4	Door Installation & Removal	7
5	Sahara Fan Installation & Removal	8
6	Operation: Bain marie	9 / 10
7	Cleaning	11

1: Electrical



Before commencing, ensure that all regulations for fire are complied with.



This appliance must be earthed and damaged cables must be replaced by a suitably qualified person!

	1 Phase Cable	3 Phase Cable
Live (L1)	Brown	Brown
L2	X	Black
L3	X	Grey
Neutral	Blue	Blue
Earth	Yellow & Green (Striped)	Yellow & Green (Striped)



A mains cable, type H07RN-F, conforming to code designation 60245 IEC 57, is supplied.

Should the supplied plug not be suitable for your socket outlet, it should be removed from the cable by a qualified electrician and replaced with the appropriate type, ensuring it's protected with the correct rating of fuse.



Units that are part of a counter are pre wired in the factory for connection on site, these counters depending on the customers specification may be fitted with either an isolator or MCB unit. In accordance with health and safety at work acts, BS codes of practice, IEE regulations, building standards, fire precautions act, and local authority and building regulations etc. all appliances/units over 3Kw require a qualified electrician to install them.



Electrical supply cable type CEN LEC H07 RN-F must be installed using a suitable isolating switch which has a minimum contact separation of 3mm in all poles.

2: Specifications & Dimensions

Model	Weight (kg)	Length	Width	Height	Power Rating (Kw)	Electrical Supply
HC2E	63	884	750	900	0.9	10amp
HC3E	78	1212	750	900	1.5	10amp
HC4E	95	1540	750	900	1.5	10amp
HC5E	111	1865	750	900	1.9	10amp
HC6E	130	2196	750	900	1.8	10amp

Hot-Cupboard & Bain-Marie (Wet Heat)

Model	Weight (kg)	Length	Width	Height	Power Rating (Kw)	Electrical Supply	1/1 Gastronorm Container Cutouts
HB2EWD	65	884	750	900	2.4	15amp	2
HB3EWD	81	1212	750	900	2.9	15amp	3
HB4EWD	100	1540	750	900	2.9	15amp	4
HB5EWD	118	1865	750	900	3.5	20amp	5
HB6EWD	138	2196	750	900	3.8	20amp	6



Gastronorm Containers are not supplied with Bain Marie units.

3: Operation: Hotcupboard

Hot storage cupboard with removable assisted 'Sahara' fan heating unit
(Refer to page 6 for details on how to remove Sahara fan).

Unit is fitted with removable sliding doors & removable rodded shelves, which are split into manageable sections to ease cleaning and maintenance.

The hot cupboard is excellent for preheating Plates & Dishes, as well as the temporary storage of precooked food whilst service is in progress e.g. Cooked meats/poultry, vegetables, sauces, etc.



These units are not designed to heat up or cook cold food.

Before using the unit for the first time, it needs to be checked that it's perfectly level.



The correct Holding temperature is dependent on the food type, amount of food in serving container, etc. Keep Doors Closed at all times, only opening to load/unload cupboard contents.

1. Connect plug to 15-Amp socket and switch on at mains socket.
2. Close doors & click the green neon on/off 'Mains' switch to the on position.
(The switch will illuminate)
3. Turn the control knob 'fully' clockwise to highest temperature & leave for 30mins.
4. After this time period has elapsed, readjust the cupboard temperature by turning knob anti-clockwise to desired holding temperature.
Containers with 'cooked' food can now be loaded (Remember to close doors)
5. When serving is complete all switches should be turned off and the 15-Amp plug removed from the socket.
6. To maintain the life of this product, all surfaces need cleaning regularly with a damp cloth.
Refer to page 11 of this manual for more info on cleaning.

3: Operation: Hotcupboard

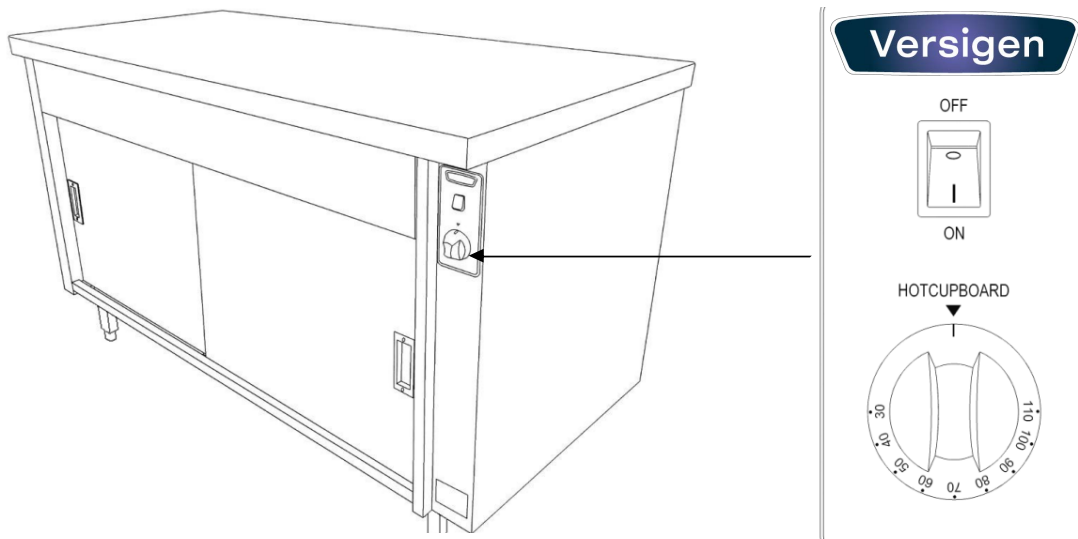

4: Door Installation & Removal

1. Hold the door at a slight angle (Fig 3) & locate the door fully into the top track.
2. Holding the door in the top track, swing the bottom of the door inwards until it comes in contact with the rear of the bottom track.
3. Gently lower the door into the bottom track, & slide the door fully to the left.

The fitment of the outer door (Door B) is the same as above, except when lowered into the bottom track slide it fully to the right. Note: It's imperative the doors must be fitted in correct order as shown in fig 2 Door 'A' first then Door 'B'.

Door removal is a reverse of the above.

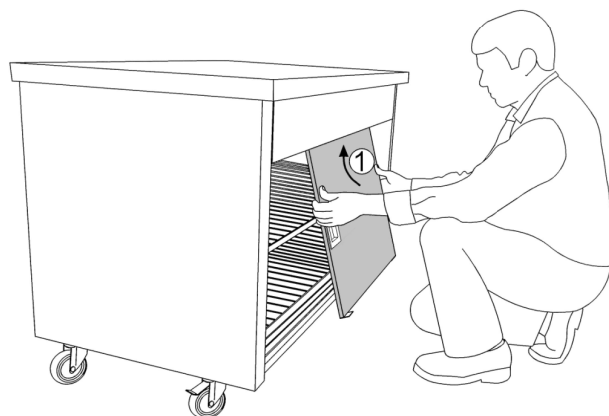
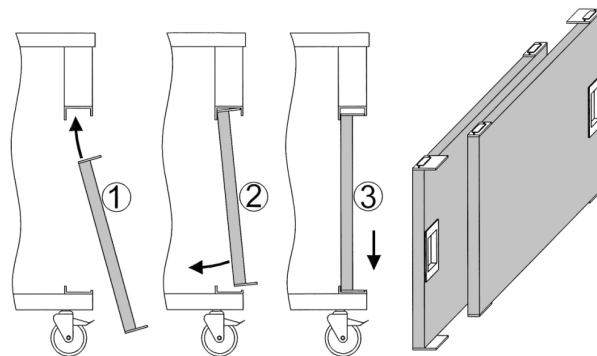

5: Sahara Fan Installation & Removal

The Sahara-Fan heater fitted provides excellent balanced heating coupled with energy savings. The unit can be easily removed & replaced for cleaning or maintenance as it has a simple bayonet & clip fastening system. The diagrams below demonstrate the removal of the hot cupboard Sahara fan. As the fan is located in the base of the cupboard, access to the Plug & socket is via the underside of the unit (fig 4).



The Sahara Fan cell is an integral part of the appliance. the fixing screw on each side provide earth bonding. Disconnect the unit from th main power supply before removing the fixing screws.

1. Locate the fixing clip on the 'Male' plug fitted to the Sahara fan press & unclip.
2. Pull the female socket off the plug
3. Remove as many rodded shelf sections as needed to allow access to the Sahara fan.
4. Remove the earth bonding fixings two on each side.
5. Lift out at a slight angle taking care not to damage the plug attached to the fan.

Fitting is a reversal of the above.



Warning: The earth bonding screws must be fitted before switching power back on



Although not shown in figure 5; the Sahara fan supplied has a protective St/steel cover over the top air intake. This shields the fan innards from any food or liquid spillage from above.

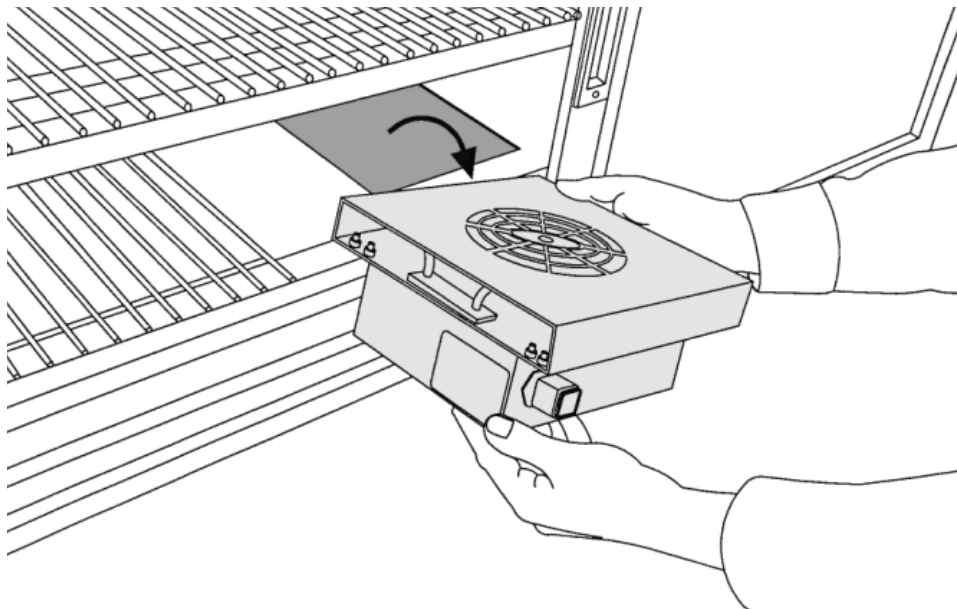

6: Operation: Bain-Marie

This Bain-Marie well can be used either dry or wet heat with an inset well designed to accommodate various combinations of interchangeable gastronorm type pans up to 150mm deep. Bain-marie units are designed to keep pre-cooked food at serving temperature and are suitable for the display of most types of hot foods.



These units are not designed to cook raw food or to heat up cold food.

Versigen were the originators of a Bain-Marie that could be either wet or dry heat. This type of system was designed to offer flexibility and was developed to eliminate the need to fit a low water level warning system or the expense of replacing burned out elements.

Wet Heat: Operation

Water level is an economic, 20mm deep [water level mark inside the well], complete with a drain valve and swing-out, run-of tube for easy emptying & cleaning.



Before using the unit for the first time, check the unit is level.

Filling The Well:

- 1. First check the drain valve inside the left-hand door of the hot-cupboard is in the closed position.*
- 2. Remove the Bain-Marie container situated directly above the 'water level indicator'.*



If required to top up the water level in mid service, use suitable heat insulated gloves when removing the hot Bain-Marie container.

- 3. Carefully fill well with water up to the water level indicator [approximately 20mm deep].*



Do not over fill with water. Too much water will impinge on performance and efficiency.

6: Operation: Bain-Marie

Wet Heat: Operation

Draining well:

1. Switch off & disconnect unit from mains power, then wait until water cools down to room temperature.
2. Open to the hot cupboard left hand door fully & securely place a suitable size container under the flexible drain hose.
3. Open drain valve & fill container.
4. Switch off valve & empty container. Repeat until well is empty.
5. Close drain valve then close hot cupboard door.
6. The well can now be cleaned (See page 11 for cleaning instructions).

Operation: General

1. Containers and lids must be in place with doors closed.
2. Switch on
3. Turn Bain-marie control to 110°C.
4. Turn Hot-cupboard control to 110°C.
5. Allow to heat up for 45min before loading containers with food.
6. After 45 min adjust the control knobs to the desired setting (usually 90°C).
7. When service is complete all switched should be turned off.

Dry Heat:

Dry heat works in the same way without any water in the well.

Heat up time will be around 30 min.

The base of the well will distort slightly and discolour when used dry this is normal.



**The correct serving temperature is dependant on the food type, amount of food in container, etc.
Do not remove lids until service is due to commence.**

7: Cleaning



Before attempting to clean the unit, please ensure that the unit is isolated from the electric supply and allowed to cool down, with all food plates and other Dishes removed from the unit.

Do not use a water jet or pressure spray to clean this appliance.

1. *Disconnect trolley from mains and wait until appliance has cooled.*
2. *Wipe clean using hot, soapy water and soft, non-abrasive cloth. Ensure that the stainless steel is wiped in straight strokes following the grain of the material.*
3. *Wipe dry using a clean cloth. Do not use scouring pads or abrasive cleaners of any type. Shelving and select inner panels can be removed to allow a deeper internal clean. Ensure all panels and fixings are replaced after cleaning operation.*
4. *Compartment should be washed and then dried with a cloth after each service.*
5. *Finish by carefully drying with a soft dry cloth or Kitchen Towels.*



Do not use scouring pads or abrasive cleaners of any type.

Do not use Solvents, bleach, Caustic Cleaners or biological powders on any surface.

Thank you for choosing Versigen!

Please note the product serial number before contacting us for service or advice:

Versigen Foodservice Equipment

1/182 Hartley Road
Smeaton Grange NSW 2567

www.versigen.com.au

1300 653 330

sales@versigen.com.au