

**Versigen Specification**

Heated Display

Recirculated forced air system  
LED Illumination  
with internal adjustable shelving  
ticket strips and front tray and  
rear sliding double glazed doors

Capacity

0.14 m3

Dimensions

Width - 830mm  
Depth - 660mm  
Height - 816mm  
Weight - 66kg

Power Rating

2.5kw  
complete with a 2m long cord set & 15amp plug

Materials

1.2mm 304 Grade St/ Steel Top & Supports  
0.7mm 430 Grade St/ Steel Internal Structure  
6mm Tempered Glass

Installation

Counter Top Flush Fit Cut Out Dimensions  
836mm x 666mm x 25mm  
Counter Support Cut Out Dimensions  
812mm x 642mm

Warning

Do not install unit in draughty conditions where the air movement is greater than 0.2mtr/sec.  
e.g.near entrance/exit doors, open windows, under air conditioning units or a ceiling mounted fan  
Ambient room conditions must not drop below 16°C .  
Ticket strips must be in place on each shelf and the front tray must not be removed

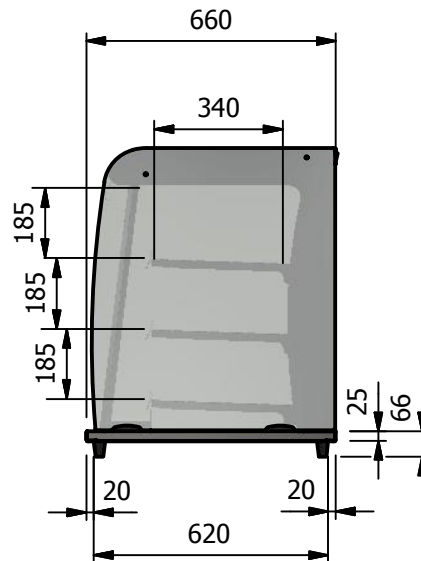
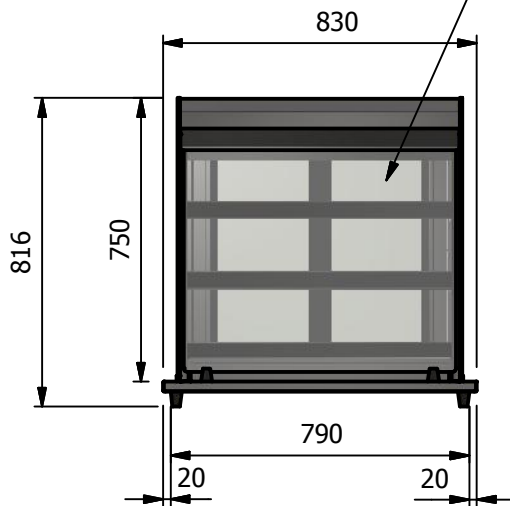

ALL SHEET METAL DIMENSIONS ARE I/S (INSIDE SIZES) (UNLESS OTHERWISE STATED)

ALL DIMENSIONS IN (mm), TOLERANCE = LINEAR ± 0.5mm, ANGULAR ± 0.5mm (OR AS STATED). ALL SHARP EDGES TO BE REMOVED FROM SHEET METAL PARTS

Product	GRAB & GO'S			Product No							
Description	D2GHF			<small>© No reproduction or publication of this drawing may be made, and no article may be manufactured or assembled in accordance with this drawing without prior written consent. This prohibition is a term of any contract relating to this drawing. Rights reserved under the Copyright Act 1956 as amended by the Design Copyright Act 1968.</small>							
Material/Finish	Thickness				Desp/Date						
Legacy P/N	Weight	66kg			Quote No.	Dwg No.	GGP-042525		Issue		
Client				SO Number	N/A		Drawn By	ABB		-	
Client Project				Approved By			Date	26/02/2019			
VERSIGEN AUSTRALIA PTY LTD, 182 HARTLEY ROAD, SMEATON GRANGE, NSW 2567, T: +61 (0)131 653 330, E: sales@versigen.com.au, Web: www.versigen.com.au							Scale	1:20	Sheet	1 / 2	<b>A4</b>

