

Versigen Specification

Heated Display
 Front control
 Solid back
 Recirculated forced air system
 LED Illumination
 with internal adjustable shelving
 ticket strips and front tray and

Capacity
 0.14 m3

Dimensions
 Width - 830mm
 Depth - 660mm
 Height - 816mm
 Weight - 60kg

Power Rating
 2.5kw
 complete with a 2m long cord set & 15amp plug

Materials
 1.2mm 304 Grade St/ Steel Top & Supports
 0.7mm 430 Grade St/ Steel Internal Structure
 6mm Tempered Glass

Installation
 Counter Top Flush Fit Cut Out Dimensions
 836mm x 666mm x 25mm
 Counter Support Cut Out Dimensions
 812mm x 642mm

Warning

Do not install unit in draughty conditions where the air movement is greater than 0.2mtr/sec.
 e.g.near entrance/exit doors, open windows, under air conditioning units or a ceiling mounted fan
 Ambient room conditions must not drop below 16°C .
 Ticket strips must be in place on each shelf and the front tray must not be removed

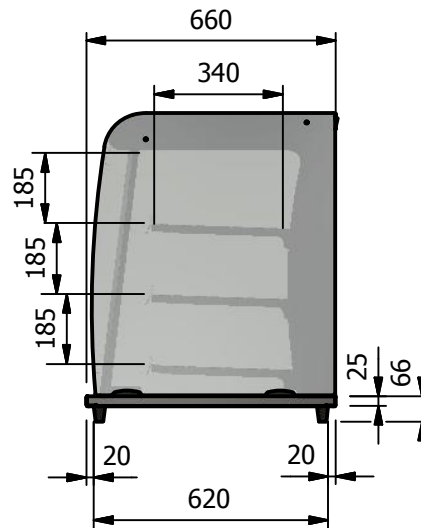
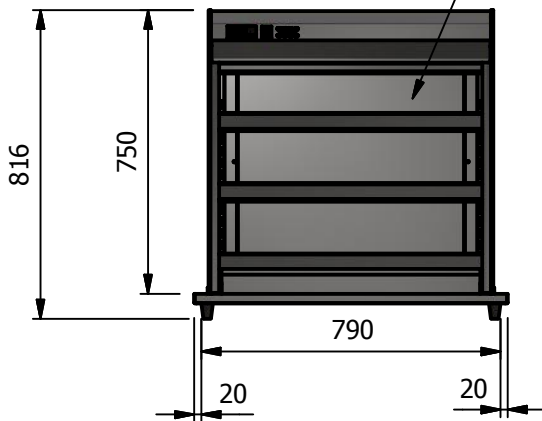

ALL SHEET METAL DIMENSIONS ARE I/S (INSIDE SIZES) (UNLESS OTHERWISE STATED)

ALL DIMENSIONS IN (mm), TOLERANCE = LINEAR ± 0.5mm, ANGULAR ± 0.5mm (OR AS STATED). ALL SHARP EDGES TO BE REMOVED FROM SHEET METAL PARTS

Product	GRAB & GO'S			Product No							
Description	D2GHFC			<small>© No reproduction or publication of this drawing may be made, and no article may be manufactured or assembled in accordance with this drawing without prior written consent. This prohibition is a term of any contract relating to this drawing. Rights reserved under the Copyright Act 1956 as amended by the Design Copyright Act 1968.</small>							
Material/Finish	Thickness			Desp/Date							
Legacy P/N	Weight	60kg		Quote No.	Dwg No.		GGP-027485		Issue		
Client				SO Number	N/A		Drawn By	ABB			
Client Project				Approved By			Date	26/02/2019			
VERSIGEN AUSTRALIA PTY LTD, 182 HARTLEY ROAD, SMEATON GRANGE, NSW 2567, T: +61 (0)131 653 330, E: sales@versigen.com.au, Web: www.versigen.com.au							Scale	1:20	Sheet	1 / 2	A4

