

Important Design Parameters

On the operators side of the Servery Counter a removable service panel is required to allow access to service heating elements etc. The dimensions of the access aperture must be no less than 997mm x 145mm.

Additionally access is required to manually operate the drain valve. Drain connection is via 15mm lever ball valve.

Warning

The unit must be manually filled with water. Capacity 20 litre. A depth of 40mm must be maintained during operation. [water level marker fitted to element cover]

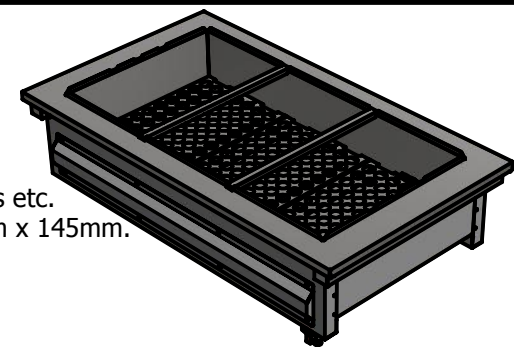

Versigen Specification

Wet Heat
Immersion heated Bainmarie Well

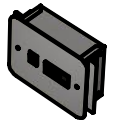

Dimensions
Width - 1158mm
Depth - 660mm
Height - 266mm
Weight - 35kg

Power Rating
3.0kw
complete with a 2m long cord set & 15amp plug

Materials
1.2mm 304 Grade St/ Steel Top, Supports & Well
0.7mm 430 Grade St/ Steel External Structure
0.7mm Galvanised Steel Undercarrage
6mm Tempered Glass
Quartz Lamps

Installation
Counter Top Flush Fit Cut Out Dimensions
1164mm x 666mm x 25mm
Counter Support Cut Out Dimensions
1140mm x 642mm

Control Box
Panel Mounted Cut Out Dimension
215mm x 165mm
2m Long Power Cable Connecting
Control Box to Base unit

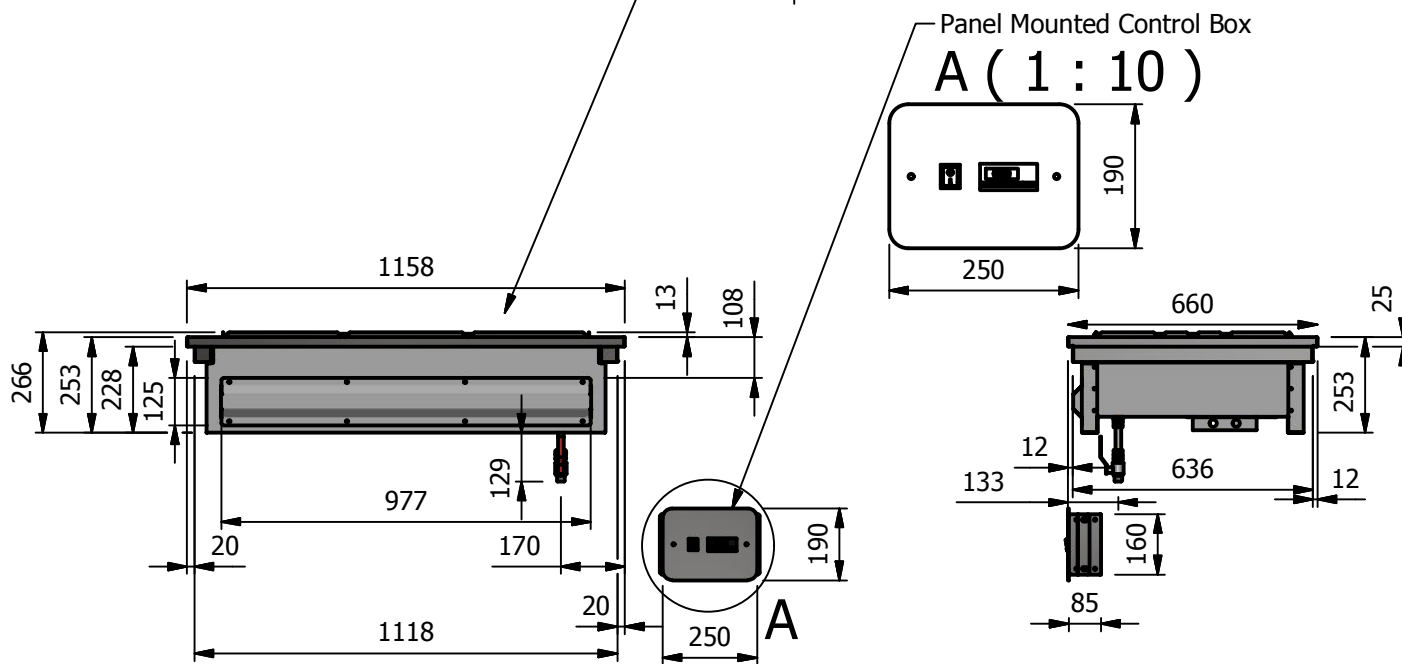

ALL SHEET METAL DIMENSIONS ARE I/S (INSIDE SIZES) (UNLESS OTHERWISE STATED)

ALL DIMENSIONS IN (mm), TOLERANCE = LINEAR ± 0.5mm, ANGULAR ± 0.5mm (OR AS STATED). ALL SHARP EDGES TO BE REMOVED FROM SHEET METAL PARTS

Product	DROP-IN RANGE			Product No		 FOODSERVICE EQUIPMENT				
Description	D3BMWNG									
Material/Finish	Thickness			Desp/Date						
Legacy P/N	Weight	35kg		Quote No.		Dwg No.	DIP-022417	Issue		
Client				SO Number	N/A	Drawn By	ABB	-		
Client Project				Approved By		Date	16/01/2019			
VERSIGEN AUSTRALIA PTY LTD, 182 HARTLEY ROAD, SMEATON GRANGE, NSW 2567, T: +61 (0)131 653 330, E: sales@versigen.com.au, Web: www.versigen.com.au						Scale	1:20	Sheet	1 / 1	A4

No reproduction or publication of this drawing may be made, and no article may be manufactured or assembled in accordance with this drawing without prior written consent. This prohibition is a term of any contract relating to this drawing. Rights reserved under the Copyright Act 1956 as amended by the Design Copyright Act 1968.