

Versigen Specification

Ambient Display
LED Illumination
with internal adjustable shelving
ticket strips and front tray and
rear sliding double glazed doors

Capacity
0.20 m3

Dimensions
Width - 1158mm
Depth - 660mm
Height - 816mm
Weight - 82kg

Power Rating
0.15kw
complete with a 2m long cord set & 10amp plug

Materials
1.2mm 304 Grade St/ Steel Top & Supports
0.7mm 430 Grade St/ Steel Internal Structure
6mm Tempered Glass

Installation
Counter Top Flush Fit Cut Out Dimensions
1164mm x 666mm x 25mm
Counter Support Cut Out Dimensions
1140mm x 642mm

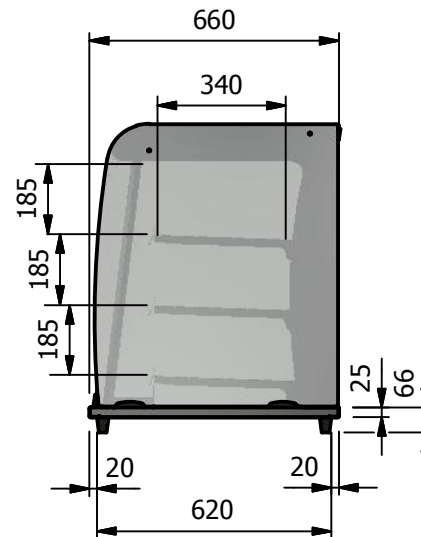
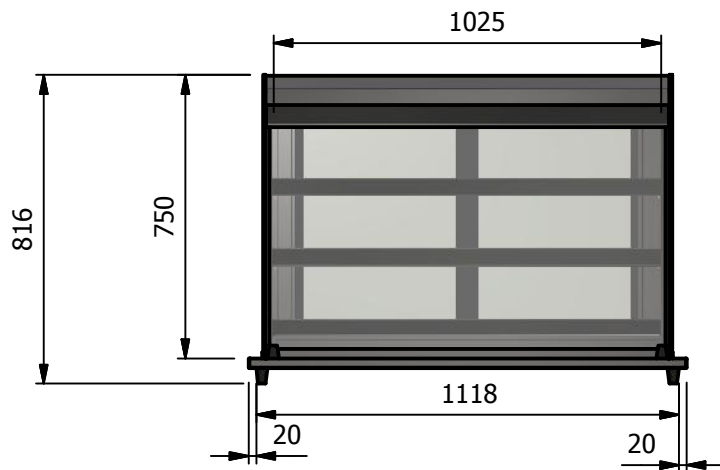

ALL SHEET METAL DIMENSIONS ARE I/S (INSIDE SIZES) (UNLESS OTHERWISE STATED)

ALL DIMENSIONS IN (mm), TOLERANCE = LINEAR ± 0.5mm, ANGULAR ± 0.5mm (OR AS STATED). ALL SHARP EDGES TO BE REMOVED FROM SHEET METAL PARTS

Product	GRAB & GO'S			Product No			
Description	D3GAF			<small>© No reproduction or publication of this drawing may be made, and no article may be manufactured or assembled in accordance with this drawing without prior written consent. This prohibition is a term of any contract relating to this drawing. Rights reserved under the Copyright Act 1956 as amended by the Design Copyright Act 1968.</small>			
Material/Finish	Thickness		Desp/Date				
Legacy P/N	Weight	82kg	Quote No.	Dwg No.	GGP-042700	Issue	
Client				SO Number	N/A	Drawn By	ABB
Client Project				Approved By		Date	26/02/2019
VERSIGEN AUSTRALIA PTY LTD, 182 HARTLEY ROAD, SMEATON GRANGE, NSW 2567, T: +61 (0)131 653 330, E: sales@versigen.com.au, Web: www.versigen.com.au				Scale	1:20	Sheet	1 / 2 A4