

**Important Design Parameters**

On the operators side of the Servery Counter a removable service panel is required to allow access to service heating elements etc. The dimensions of the access aperture must be no less than 1325mm x 145mm.

Additionally access is required to manually operate the drain valve. Drain connection is via 15mm lever ball valve.

**Warning**

The unit must be manually filled with water. Capacity 27 litre. A depth of 40mm must be maintained during operation. [water level marker fitted to element cover]

**Versigen Specification**

**Wet Heat**  
Immersion heated Bainmarie Well

**Dimensions**  
Width - 1486mm  
Depth - 660mm  
Height - 666mm  
Weight - 44kg

**Power Rating**  
4kw  
complete with a 2m long cord set & 20amp plug

**Materials**  
1.2mm 304 Grade St/ Steel Top, Supports & Well  
0.7mm 430 Grade St/ Steel External Structure  
0.7mm Galvanised Steel Undercarrage  
6mm Tempered Glass  
Quartz Lamps

**Installation**  
Counter Top Flush Fit Cut Out Dimensions  
1492mm x 666mm x 25mm  
Counter Support Cut Out Dimensions  
1468mm x 642mm

**Control Box**  
Panel Mounted Cut Out Dimension  
215mm x 165mm  
2m Long Power Cable Connecting  
Control Box to Base unit

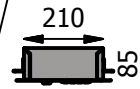
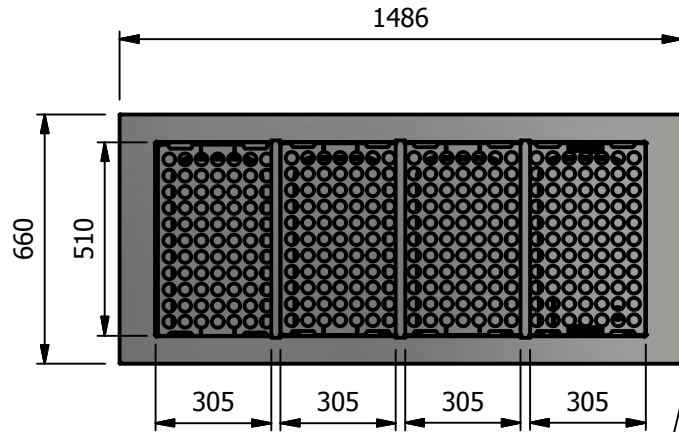

Panel Mounted Control Box

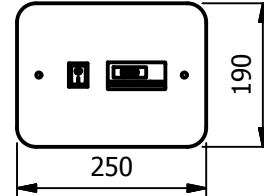

A ( 1 : 10 )

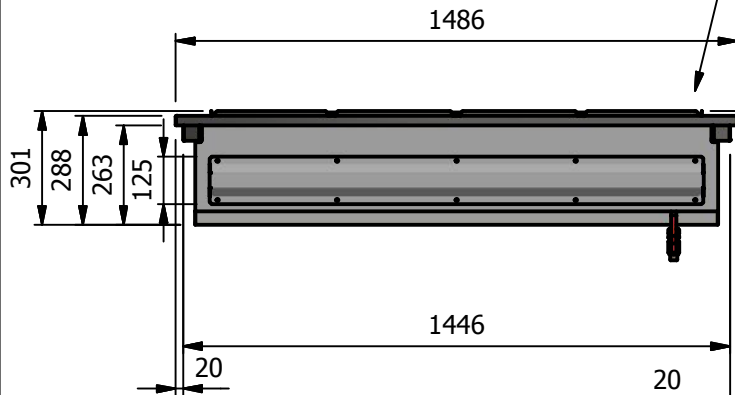
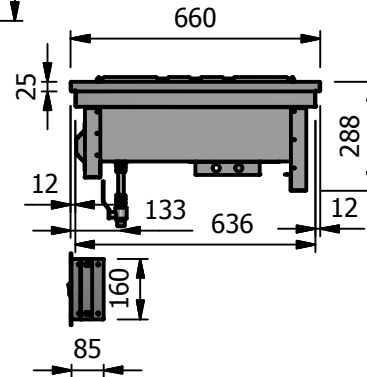
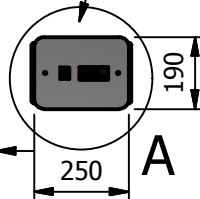

ALL SHEET METAL DIMENSIONS ARE I/S (INSIDE SIZES) (UNLESS OTHERWISE STATED)

ALL DIMENSIONS IN (mm), TOLERANCE = LINEAR ± 0.5mm, ANGULAR ± 0.5mm (OR AS STATED). ALL SHARP EDGES TO BE REMOVED FROM SHEET METAL PARTS

Product	DROP-IN RANGE			Product No	 FOODSERVICE EQUIPMENT
Description	D4BMWNG				
Material/Finish	Thickness		Desp/Date		No reproduction or publication of this drawing may be made, and no article may be manufactured or assembled in accordance with this drawing without prior written consent. This prohibition is a term of any contract relating to this drawing. Rights reserved under the Copyright Act 1956 as amended by the Design Copyright Act 1968.
Legacy P/N	Weight	44kg	Quote No.	Dwg No.	
Client			SO Number	N/A	DIP-022426
Client Project			Approved By		Issue
VERSIGEN AUSTRALIA PTY LTD, 182 HARTLEY ROAD, SMEATON GRANGE, NSW 2567, T: +61 (0)131 653 330, E: sales@versigen.com.au, Web: www.versigen.com.au					Drawn By ABB Date 16/01/2019 Scale 1:20 Sheet 1 / 1 A4