

Drain with valve below.
Connect into the main drain,
or placed a vessel under
to catch excess water

← AirFlow

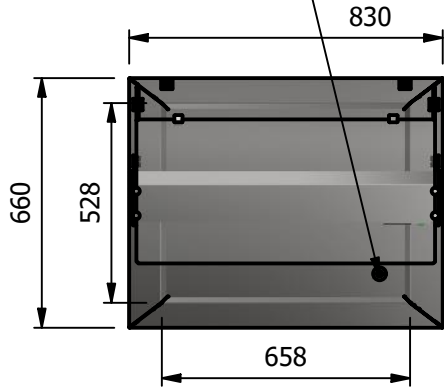

Alternative Vent
Panel Routing

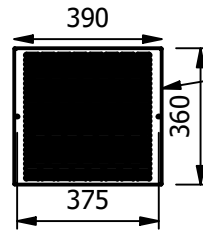
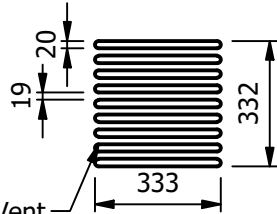

Standard Vent
Grilles 333mm x 333mm

Plenum Duct

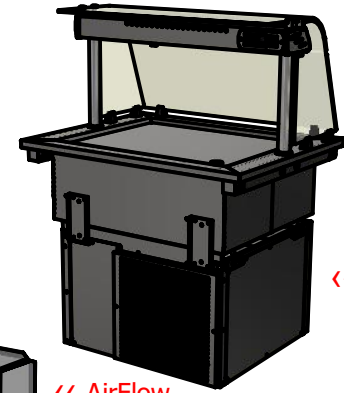
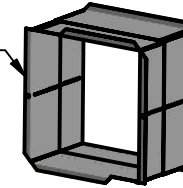

← AirFlow

← AirFlow

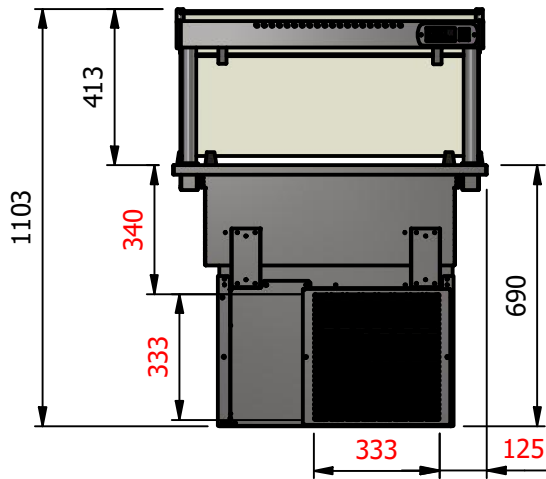

← AirFlow

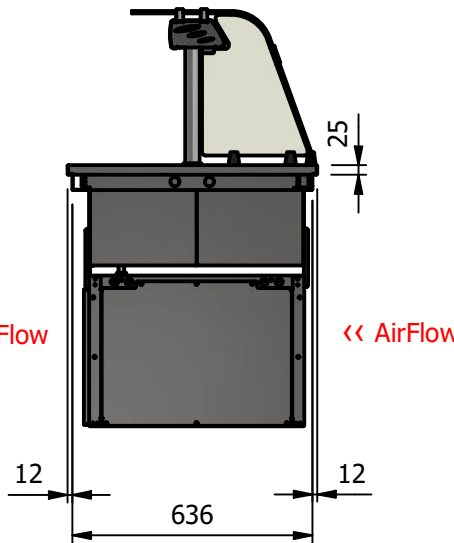

← AirFlow

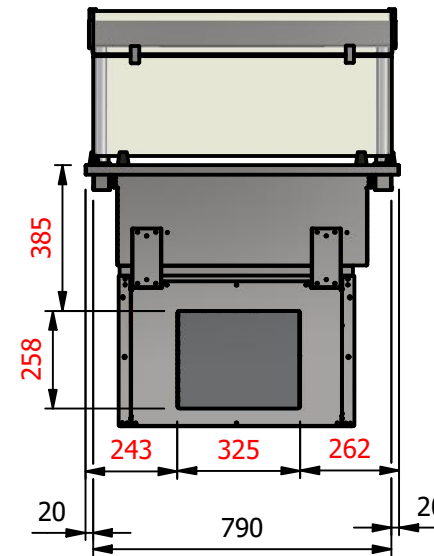

Specification

Dimensions

Width - 830mm

Depth - 660mm

Height - 1103mm

Weight - 70kg

Recessed chilled area - 658mm x 528mm

Power Rating

1.0 kw

complete with a 2m long cord set & plug

Materials

0.7mm 430 Grade St/Steel Gantry Hood

1.2mm 304 Grade St/ Steel Top & Supports

1.2mm 430 Grade St Steel Ancillary Parts

1.2mm Galvanised Steel Inner Supports

6mm Tempered Glass

LED Illumination

Installation

Counter Top Flush Fit Cut Out Dimensions

836mm x 666mm x 25mm

Counter Support Cut Out Dimensions

812mm x 642mm

ALL SHEET METAL DIMENSIONS ARE I/S (INSIDE SIZES) (UNLESS OTHERWISE STATED)

ALL DIMENSIONS IN (mm), TOLERANCE = LINEAR ± 0.5mm, ANGULAR ± 0.5mm (OR AS STATED). ALL SHARP EDGES TO BE REMOVED FROM SHEET METAL PARTS

Product	DROP-IN RANGE			Product No						
Description	D2FTF									
Material/Finish	Thickness			Desp/Date						
Legacy P/N	Weight	70kg		Quote No.						
Client				SO Number	STANDARD		Dwg No.	DIP-101717-1		
Client Project				Approved By			Drawn By	N.Raymen		
							Date	26/08/2021		
Versigen Foodservice Equipment 1/182 Hartley Road Smeaton Grange NSW 2567 Tel: 1300 653 330 Email: sales@versigen.com.au							Scale	1 : 20	Sheet	1 / 2
										A4

No reproduction or publication of this drawing may be made, and no article may be manufactured or assembled in accordance with this drawing without prior written consent. This prohibition is a term of any contract relating to this drawing. Rights reserved under the Copyright Act 1956 as amended by the Design Copyright Act 1968.

