

**Important Design Parameters**

Allowances must be made for air venting.

The under slung compressor must have an unrestricted air flow.

Proper venting must be provided ensuring cool air from the room can be drawn in through the condensing coil and out the other side.

The 'Plenum Duct' supplied should be fitted between the unit & the shop-fitted counter panels.

**Warning**

Do not install unit in draughty conditions where the air movement is greater than 0.2mtr/sec.

e.g. near entrance/exit doors, open windows, under air conditioning units or a ceiling mounted fan

Do not install units where there is high radiated heat, e.g. direct sunlight, room heaters, or bright spot lights.

Ambient room conditions must not exceed 25°C or a relative humidity of 60%.

Blocked vents will cause reduced refrigeration efficiency and lead to malfunction

Drain with valve below.  
Connect into the main drain,  
or placed a vessel under  
to catch excess water

**Important**  
Position of air intake vent  
This area must be clear for air flow

AirFlow >>

<< AirFlow

Plenum Duct

Alternative Vent  
Panel Routing

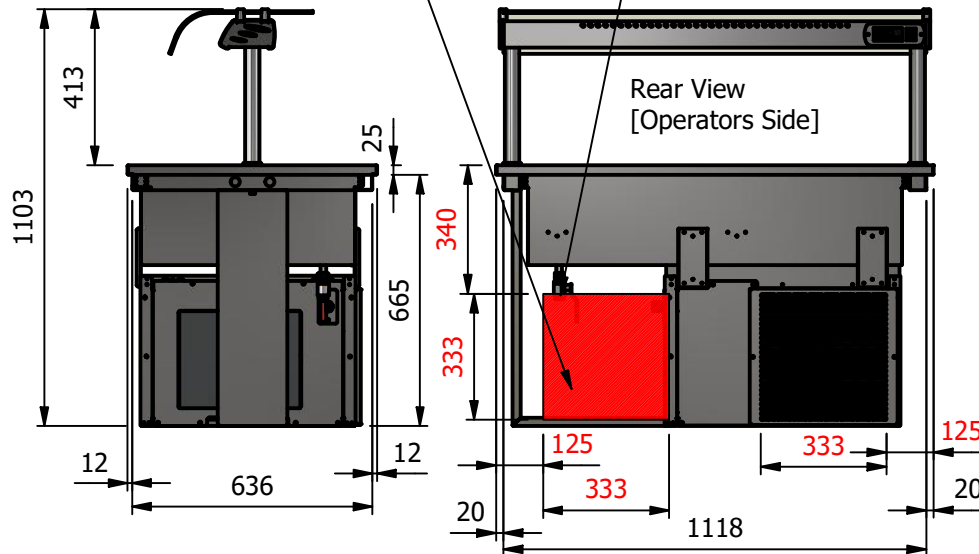
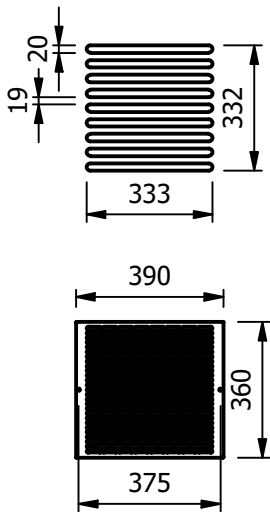

**Specification**

**Dimensions**

Width - 1158mm

Depth - 660mm

Height - 1103mm

Weight - 70kg

Recess chilled area - 986mm x 528mm

**Power Rating**

1.0 kw

complete with a 2m long cord set & plug

**Materials**

0.7mm 430 Grade St/Steel Gantry Hood

1.2mm 304 Grade St/ Steel Top & Supports

1.2mm 430 Grade St Steel Ancillary Parts

1.2mm Galvanised Steel Inner Supports

6mm Tempered Glass

LED Illumination

**Installation**

Counter Top Flush Fit Cut Out Dimensions

1164mm x 666mm x 25mm

Counter Support Cut Out Dimensions

1140mm x 642mm

ALL SHEET METAL DIMENSIONS ARE I/S (INSIDE SIZES) (UNLESS OTHERWISE STATED)

ALL DIMENSIONS IN (mm), TOLERANCE = LINEAR ± 0.5mm, ANGULAR ± 0.5mm (OR AS STATED). ALL SHARP EDGES TO BE REMOVED FROM SHEET METAL PARTS

Product	DROP-IN RANGE			Product No		No reproduction or publication of this drawing may be made, and no article may be manufactured or assembled in accordance with this drawing without prior written consent. This prohibition is a term of any contract relating to this drawing. Rights reserved under the Copyright Act 1956 as amended by the Design Copyright Act 1968.		
Description	D3FT							
Material/Finish	Thickness		Desp/Date					
Legacy P/N	Weight	70kg	Quote No.					
Client			SO Number	STANDARD	Dwg No.	DIP-101513-1	Issue	
Client Project			Approved By		Drawn By	N.Raymen		-
Versigen Foodservice Equipment 1/182 Hartley Road Smeaton Grange NSW 2567 Tel: 1300 653 330 Email: sales@versigen.com.au					Date	26/08/2021		
					Scale	1 : 20	Sheet	1 / 2