

Important Design Parameters

Allowances must be made for air venting.

The under slung compressor must have an unrestricted air flow.

Proper venting must be provided ensuring cool air from the room can be drawn in through the condensing coil and out the other side.

The 'Plenum Duct' supplied should be fitted between the unit & the shop-fitted counter panels.

Warning

Do not install unit in draughty conditions where the air movement is greater than 0.2mtr/sec.

e.g. near entrance/exit doors, open windows, under air conditioning units or a ceiling mounted fan
Do not install units where there is high radiated heat, e.g. direct sunlight, room heaters, or bright spot lights.

Ambient room conditions must not exceed 25°C or a relative humidity of 60%.

Blocked vents will cause reduced refrigeration efficiency and lead to malfunction

Drain with valve below.
Connect into the main drain,
or placed a vessel under
to catch excess water

Important
Position of air intake vent
This area must be clear for air flow

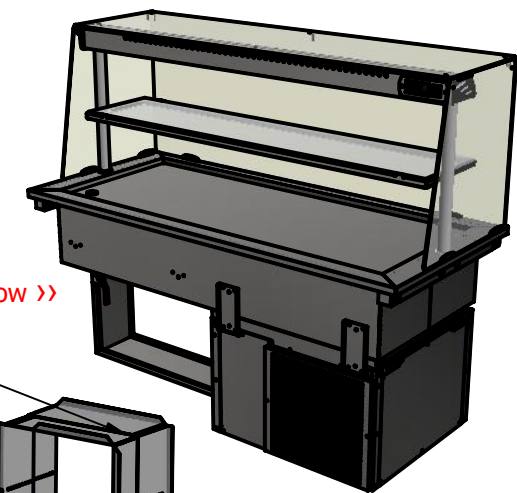
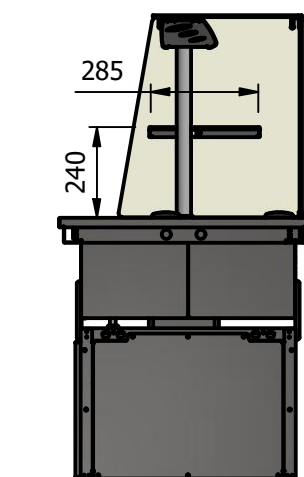
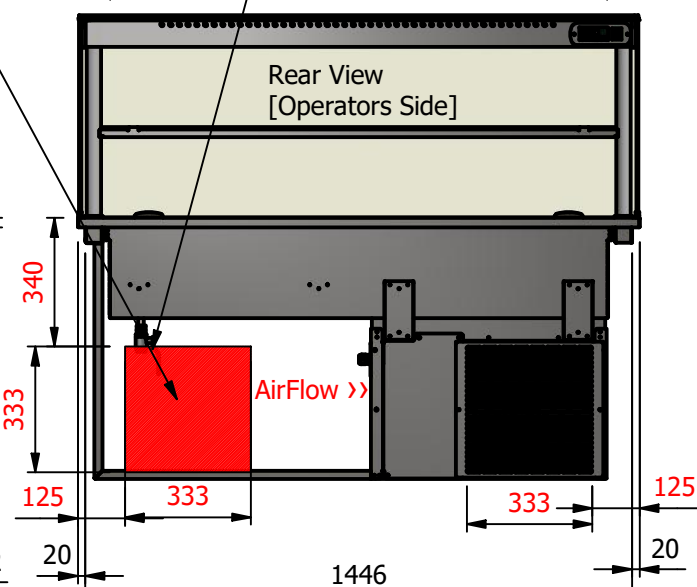
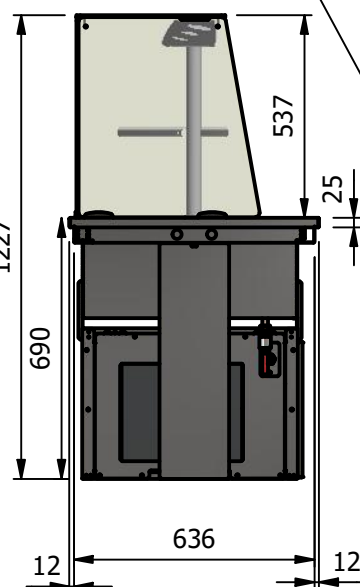
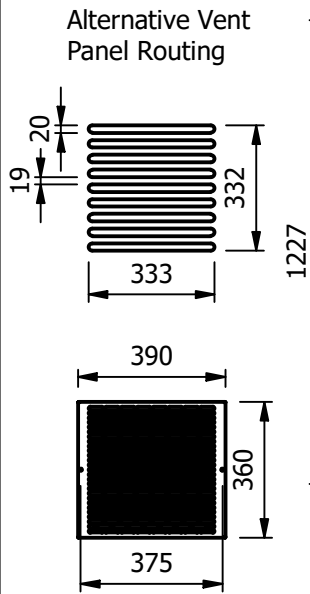

Specification

Dimensions

Width - 1486mm

Depth - 660mm

Height - 1227mm

Weight - 90kg

Recess chilled area - 1314mm x 528mm

Power Rating

1.0 kw

complete with a 2m long cord set & plug

Materials

0.7mm 430 Grade St/Steel Gantry Hood

1.2mm 304 Grade St/ Steel Top & Supports

1.2mm 430 Grade St Steel Ancillary Parts

1.2mm Galvanised Steel Inner Supports

6mm Tempered Glass

LED Illumination

Installation

Counter Top Flush Fit Cut Out Dimensions

1492mm x 666mm x 25mm

Counter Support Cut Out Dimensions

1468mm x 642mm

ALL SHEET METAL DIMENSIONS ARE I/S (INSIDE SIZES) (UNLESS OTHERWISE STATED)

ALL DIMENSIONS IN (mm), TOLERANCE = LINEAR ± 0.5mm, ANGULAR ± 0.5mm (OR AS STATED). ALL SHARP EDGES TO BE REMOVED FROM SHEET METAL PARTS

Product	DROP-IN RANGE			Product No				
Description	D4FTDSL							
Material/Finish	Thickness		Desp/Date					
Legacy P/N	Weight	90kg	Quote No.					
Client			SO Number	STANDARD	Dwg No.	DIP-101812-1	Issue	
Client Project			Approved By		Drawn By	N.Raymen		
Versigen Foodservice Equipment 1/182 Hartley Road Smeaton Grange NSW 2567 Tel: 1300 653 330 Email: sales@versigen.com.au					Date	26/08/2021		
					Scale	1 : 20	Sheet	1 / 2
								A4

No reproduction or publication of this drawing may be made, and no article may be manufactured or assembled in accordance with this drawing without prior written consent. This prohibition is a term of any contract relating to this drawing. Rights reserved under the Copyright Act 1956 as amended by the Design Copyright Act 1968.