

**Important Design Parameters**

Allowances must be made for air venting.

The under slung compressor must have an unrestricted air flow.

Proper venting must be provided ensuring cool air from the room can be drawn in through the condensing coil and out the other side.

The 'Plenum Duct' supplied should be fitted between the unit & the shop-fitted counter panels.

**Warning**

Do not install unit in draughty conditions where the air movement is greater than 0.2mtr/sec.

e.g.near entrance/exit doors, open windows, under air conditioning units or a ceiling mounted fan

Do not install units where there is high radiated heat, e.g. direct sunlight, room heaters, or bright spot lights.

Ambient room conditions must not exceed 25°C or a relative humidity of 60%.

Blocked vents will cause reduced refrigeration efficiency and lead to malfunction

Drain with valve below.  
Connect into the main drain,  
or placed a vessel under  
to catch excess water

**Important**  
Position of air intake vent  
This area must be clear for air flow

**Alternative Vent Panel Routing**

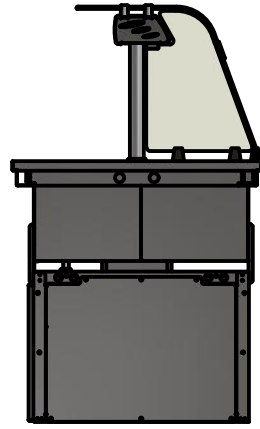
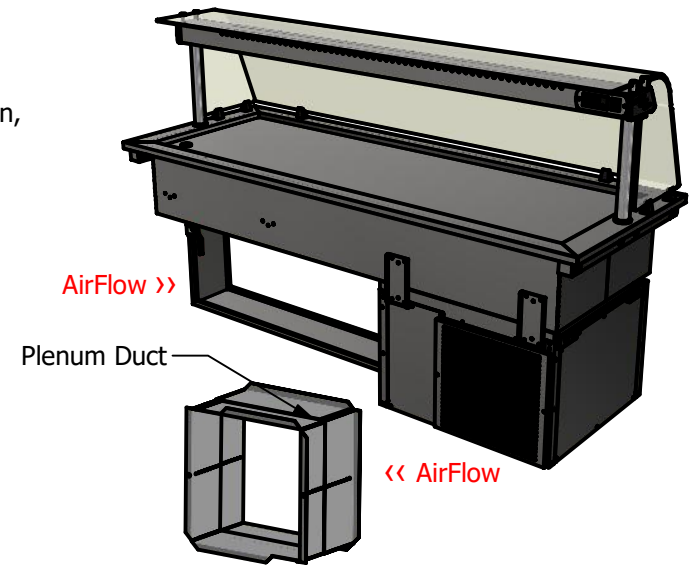
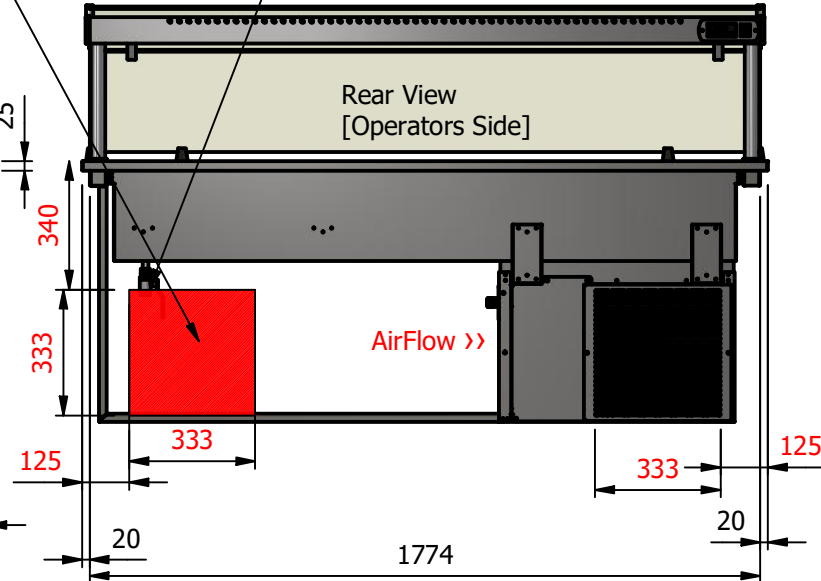
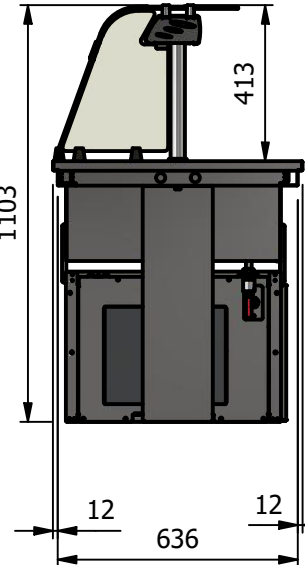
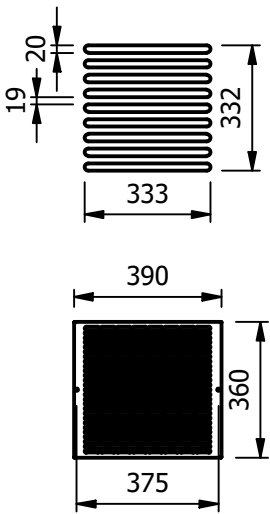

**Specification**

Dimensions

Width - 1814mm

Depth - 660mm

Height - 1103mm

Weight - 105kg

Recess chilled area - 1642mm x 528mm

Power Rating

1.0 kw

complete with a 2m long cord set & plug

Materials

0.7mm 430 Grade St/Steel Gantry Hood

1.2mm 304 Grade St/ Steel Top & Supports

1.2mm 430 Grade St Steel Ancillary Parts

1.2mm Galvanised Steel Inner Supports

6mm Tempered Glass

LED Illumination

Installation

Counter Top Flush Fit Cut Out Dimensions

1820mm x 666mm x 25mm

Counter Support Cut Out Dimensions

1796mm x 642mm

ALL SHEET METAL DIMENSIONS ARE I/S (INSIDE SIZES) (UNLESS OTHERWISE STATED)

ALL DIMENSIONS IN (mm), TOLERANCE = LINEAR ± 0.5mm, ANGULAR ± 0.5mm (OR AS STATED). ALL SHARP EDGES TO BE REMOVED FROM SHEET METAL PARTS

Product	DROP-IN RANGE			Product No				
Description	D5FTF							
Material/Finish	Thickness		Desp/Date					
Legacy P/N	Weight	105kg	Quote No.					
Client			SO Number	STANDARD	Dwg No.	DIP-101720-1	Issue	
Client Project			Approved By		Drawn By	N.Raymen		
					Date	26/08/2021		
Versigen Foodservice Equipment 1/182 Hartley Road Smeaton Grange NSW 2567 Tel: 1300 653 330 Email: sales@versigen.com.au					Scale	1 : 20	Sheet	1 / 2